

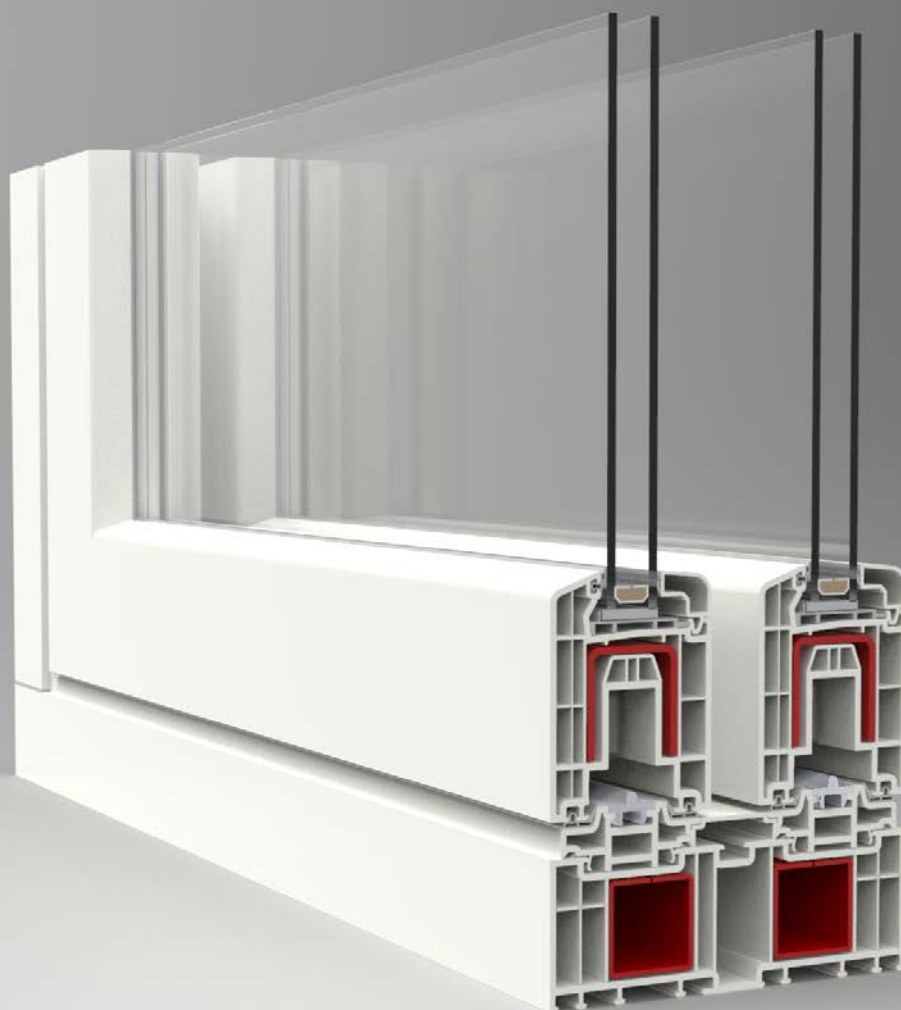

HS76 LIFT&SLIDE

FABRICATION MANUAL

deceuninck



Fabrication Manual

April 2018



innovation



ecology



design

Building a sustainable home

	Page Number
1. System Overview	1.1
Main profiles	1.2 – 1.3
Auxiliary profiles	1.4
Glazing beads	1.5
Auxiliary products	1.6 – 1.7
Opening types /HS Maximum Dimensions	1.8
Product Applications	1.9 – 1.10
2. Cutting Sizes	2.1 – 2.10
3. Fabrication	
Bottom Frame Applications	3.1 – 3.2
Drainage & Decompression	3.4 – 3.8
HS76 welding support block	3.9
Corner cleaning	3.10
Gasket types according to door types	3.11
Locking milling details	3.12
Connection details of locking profile and frame	3.13 – 3.17
Preparation of alum.bottom frame	3.18
Applications of fixed sash	3.19
Auxiliary profile details	3.20 – 3.36
4. Hardware	4.1 – 4.6
5. Sections	5.1 – 5.16

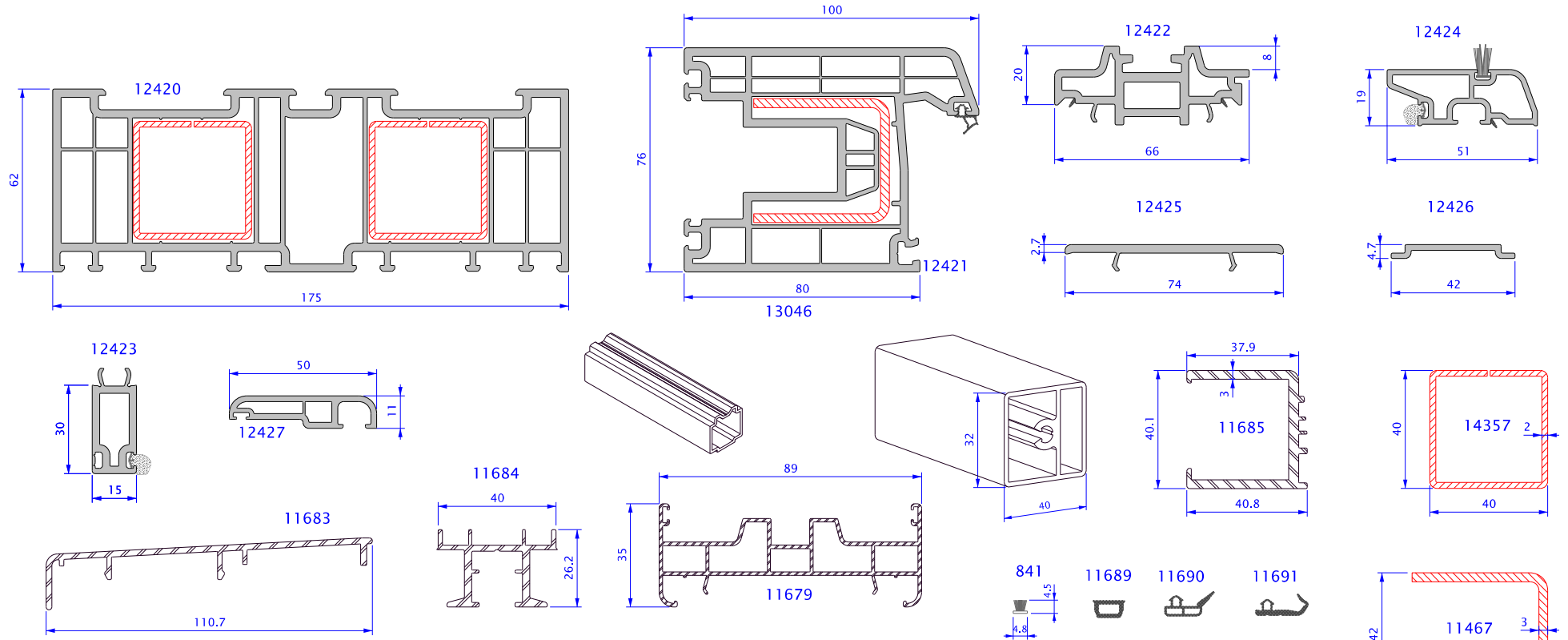

38 mm Threshold

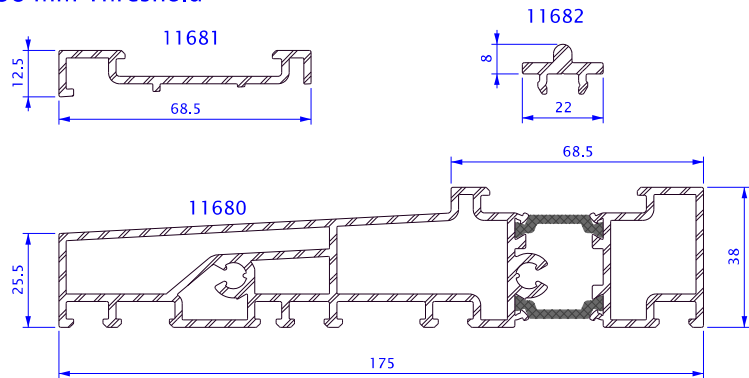

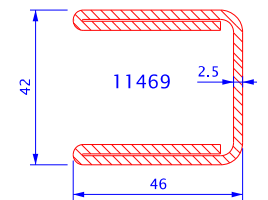
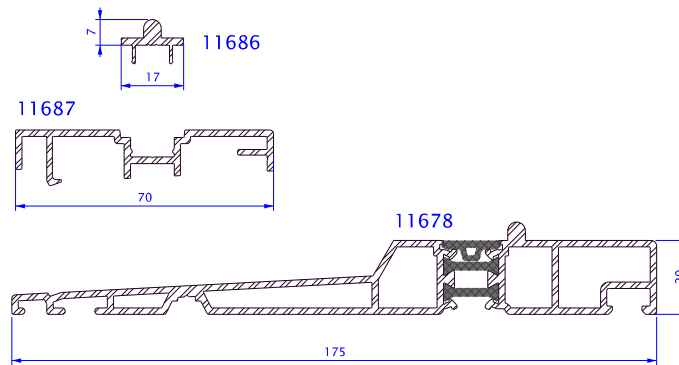

20 mm Threshold

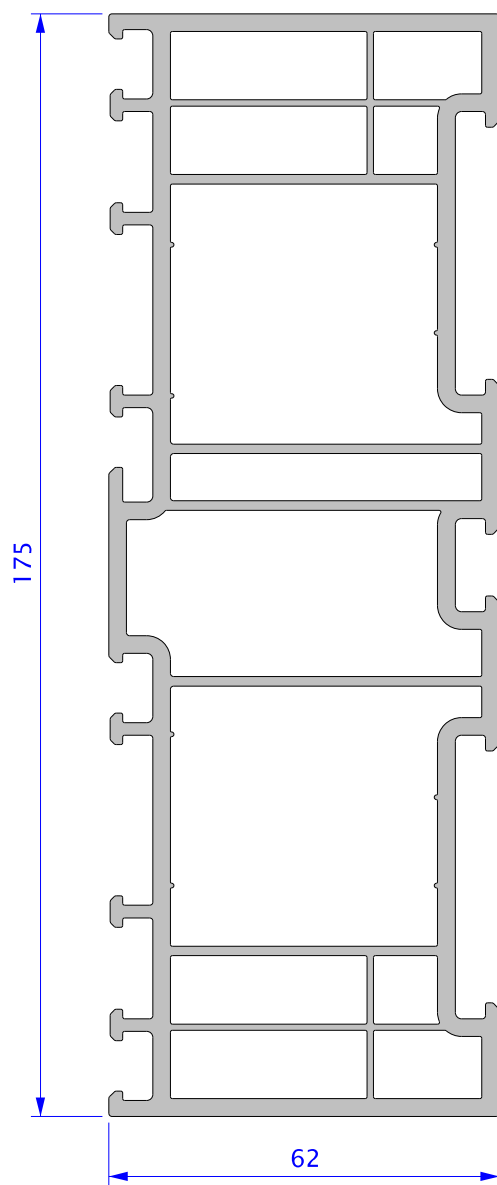

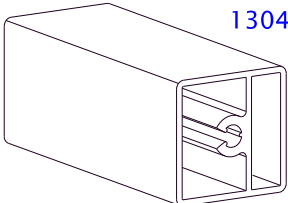

Deceuninck has the rights to change this tec.docx without any prior notice

The materials used with	Reinforcement		s (mm)	Ix (cm ⁴)	Iy (cm ⁴)
 <p>13046</p>	<p>14357 40 x 40</p>		<p>2</p>	<p>7.14</p>	<p>7.14</p>

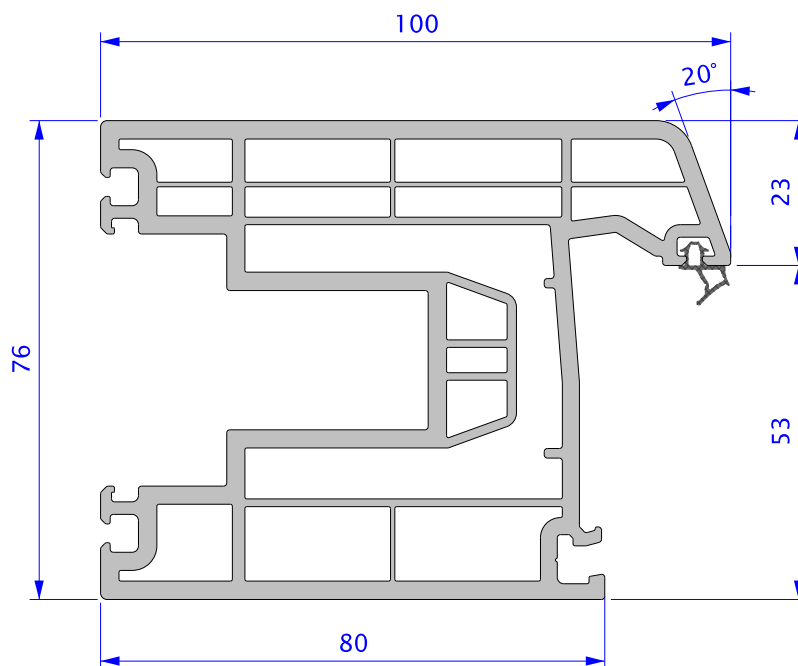

The materials used with

Reinforcement

s
(mm)

I_x
(cm⁴)

I_y
(cm⁴)

11690



11691



11467

43x42x46x3

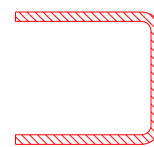

3

11.19

8.14

11469

43x42x46x2.5

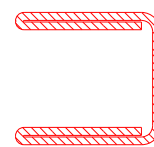

3

15.09

10.25

11685

40.8x40.1x37.9
(Aluminium)

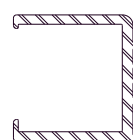







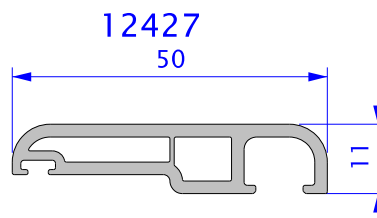
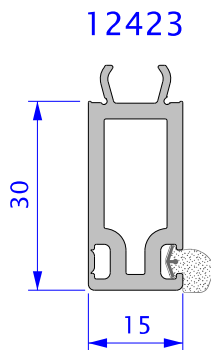
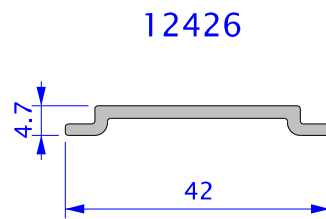
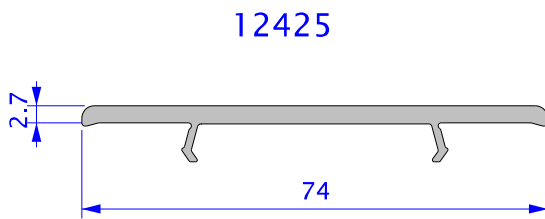
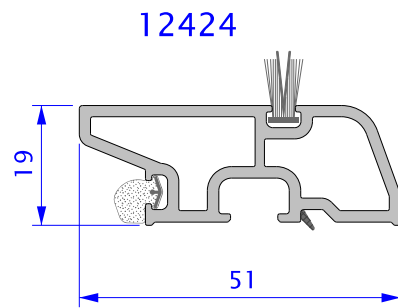
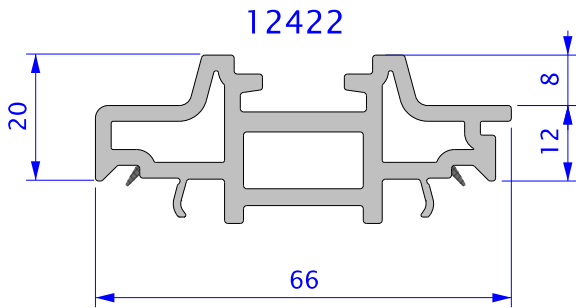



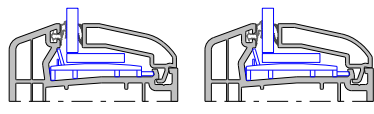

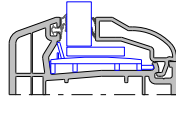

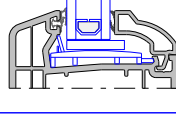

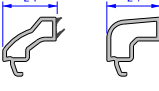
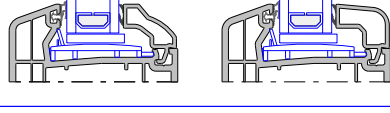

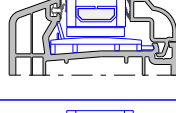

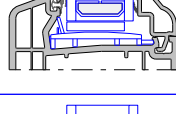
3

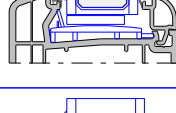
9.30

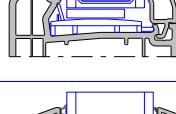
5.80

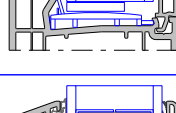

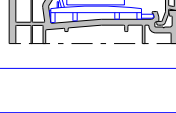
GLAZING THICKNESS (mm)		GLAZING BEADS	APPLICATION DETAILS
4 mm		12642 	
12 mm		12342 	
20 mm		12641 	
24 mm		12640 12645 	
26 mm		12341 	
30 mm		12340 	
32 mm		12643 	
36 mm		12650 	
38 mm		12648 	
44 mm		12649 	

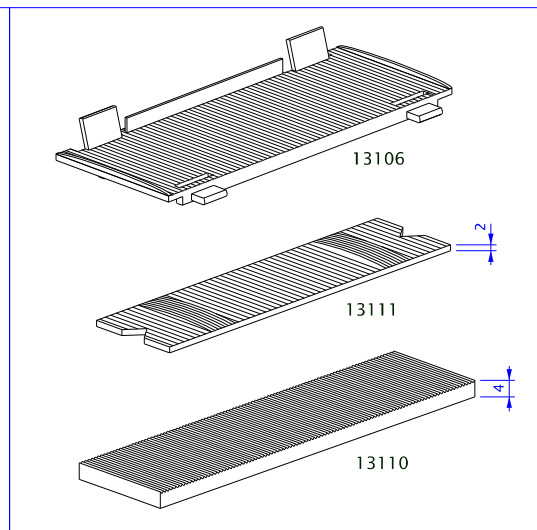
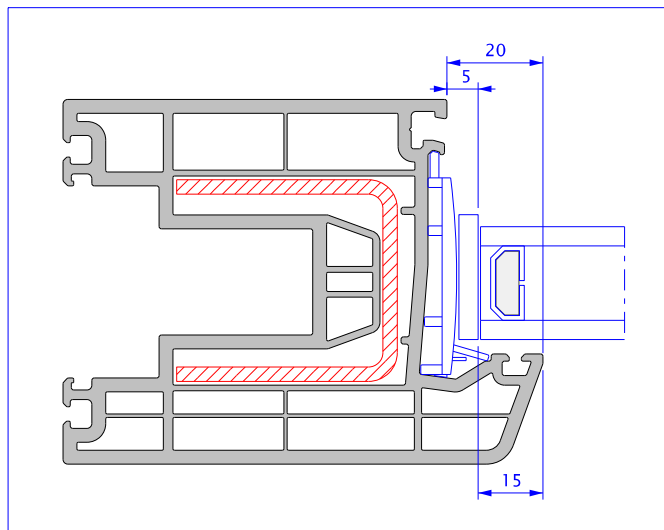

HS76 LIFT&SLIDE

HS76 ALUM. THRESHOLD 38 mm APPLICATION

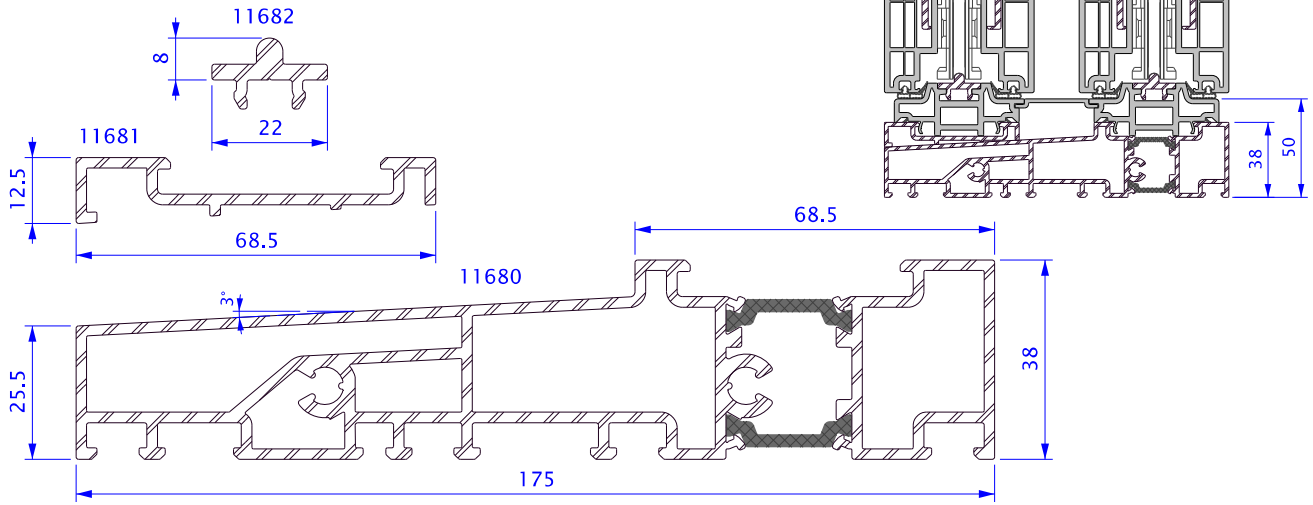

HS76 ALUM. THRESHOLD 20 mm APPLICATION

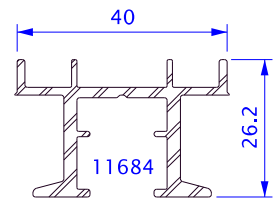
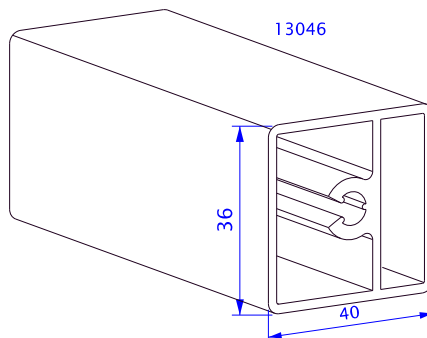
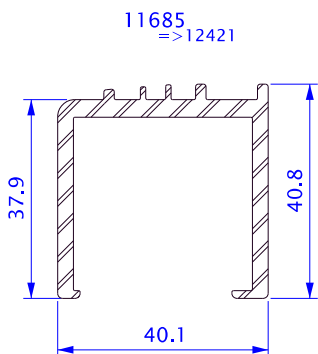
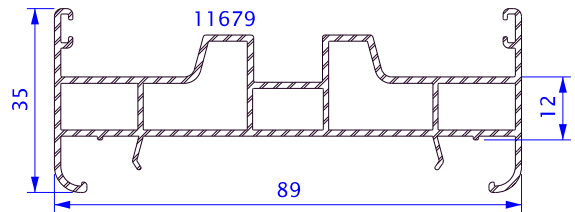
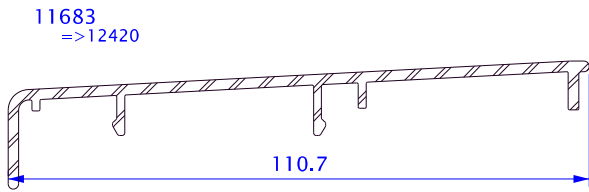
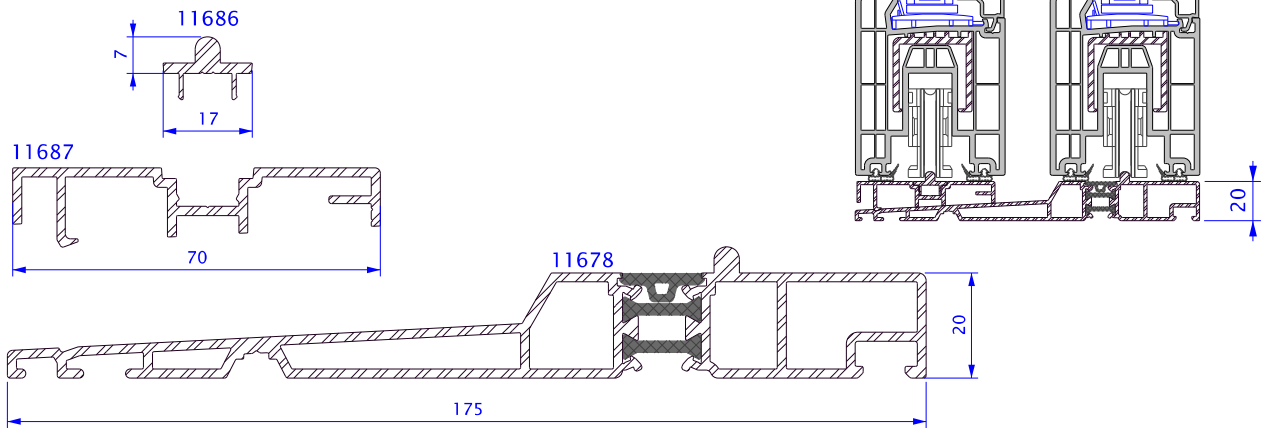

11694

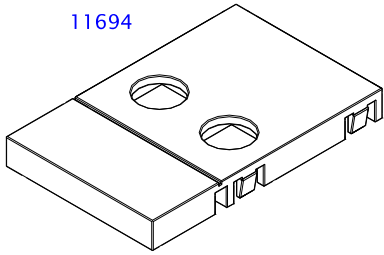

11695

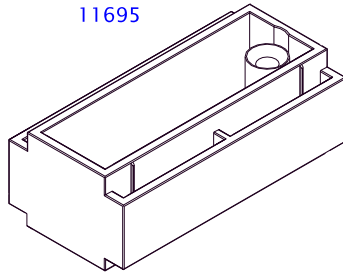

11696
(Frame 12421)

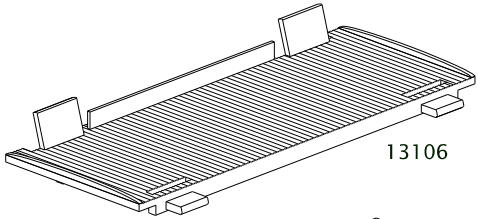
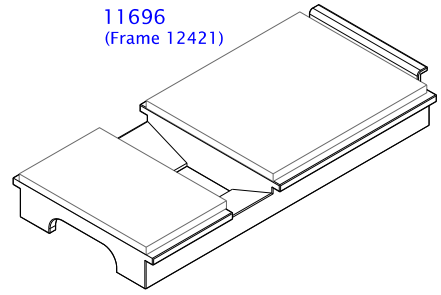

13106

11690



11691



11697
(Frame 11680)

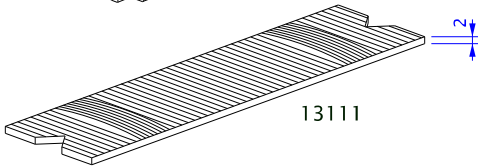
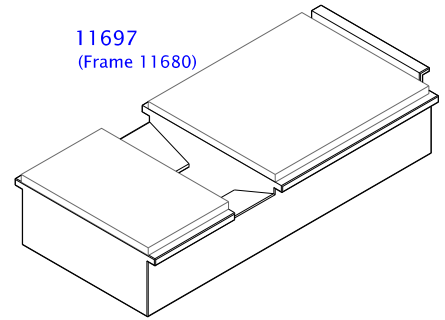

13111

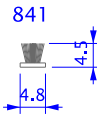

841

11689

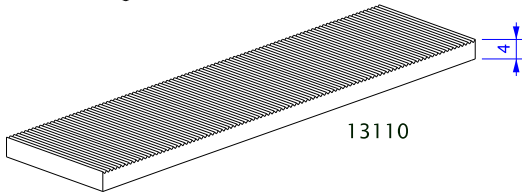

13110

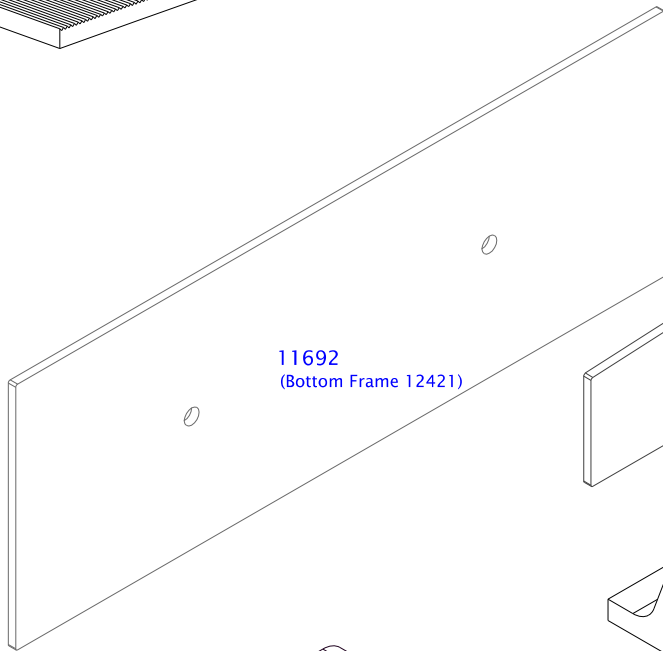

11692
(Bottom Frame 12421)

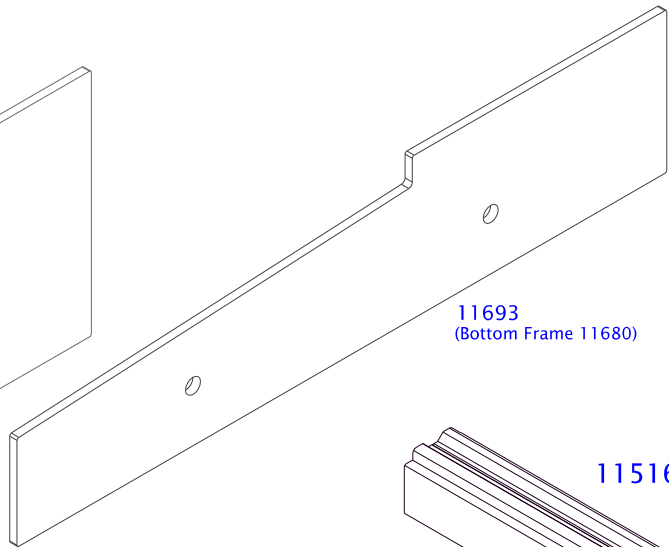

11693
(Bottom Frame 11680)

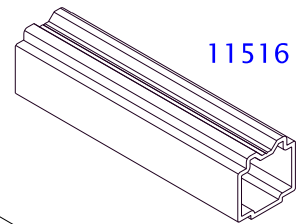

11516

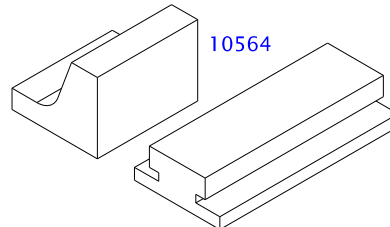

10564

10563

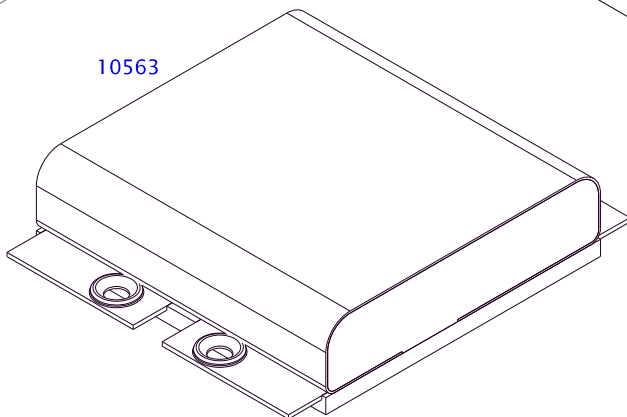

11699

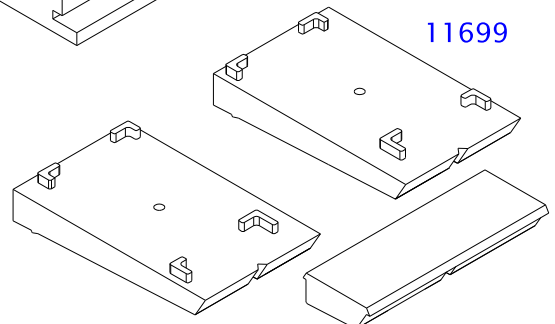

A SCHEMA

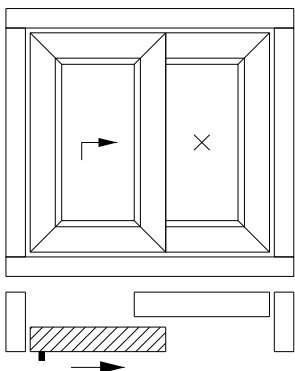

A SCHEMA

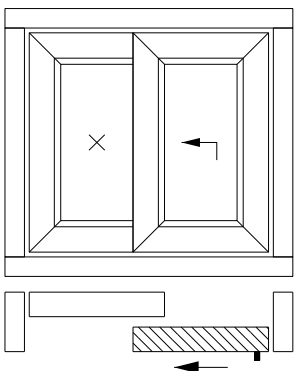

D SCHEMA

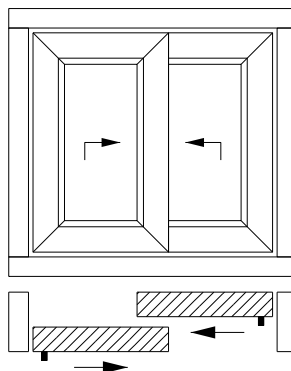

G3 SCHEMA

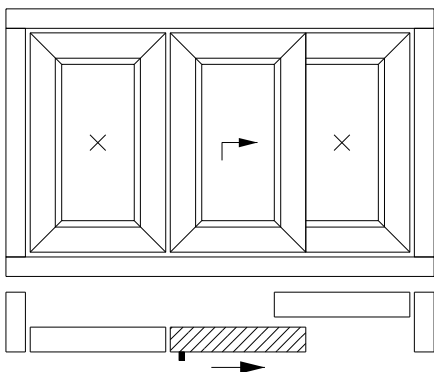

G3 SCHEMA

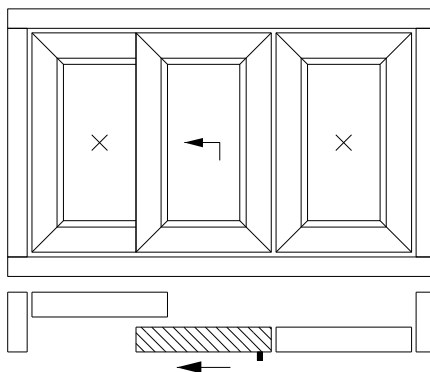

C SCHEMA

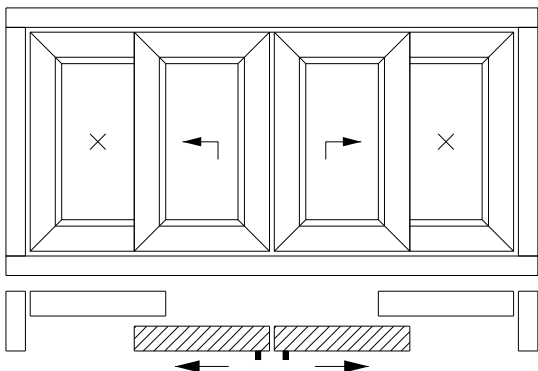

F SCHEMA

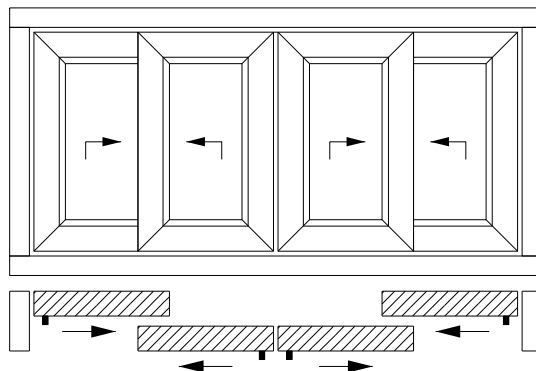

HS76 MAXIMUM DIMENSIONS

The maximum dimensions (width / height) of HS door are given in the table below. The maximum areas must not be exceeded

	2 Sashes			> 2 Sashes		
	Width (m)	Height (m)	Max.Area (m ²)	Width (m)	Height (m)	Max.Area (m ²)
White	6.5	2.6	12.0	6.5	2.6	13.0
Laminated	5.0	2.2	10.0	6.5	2.2	13.0

* Minimum frame width with 2 sashes applications is 1360 mm.

* Maximum sash weight (included glass) is 300 kg for HS76 System accessories. If the sash weight is more than 300 kg, roller set that has the 400 kg capacity can be used

* There are two options for bottom frame applications

1. 12420 – HS76 frame profile
2. 11680 – HS76 aluminium threshold 38 mm
3. 11678 – HS76 aluminium threshold 20 mm

* As shown in the sections below, the preparation of 3 frames are different at the bottom

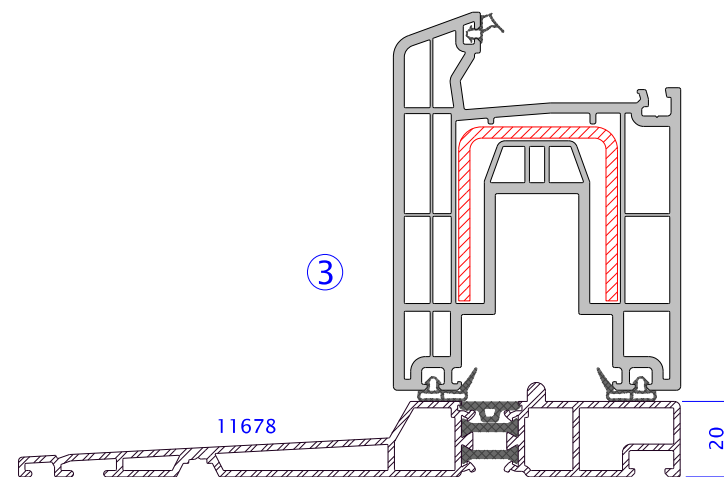
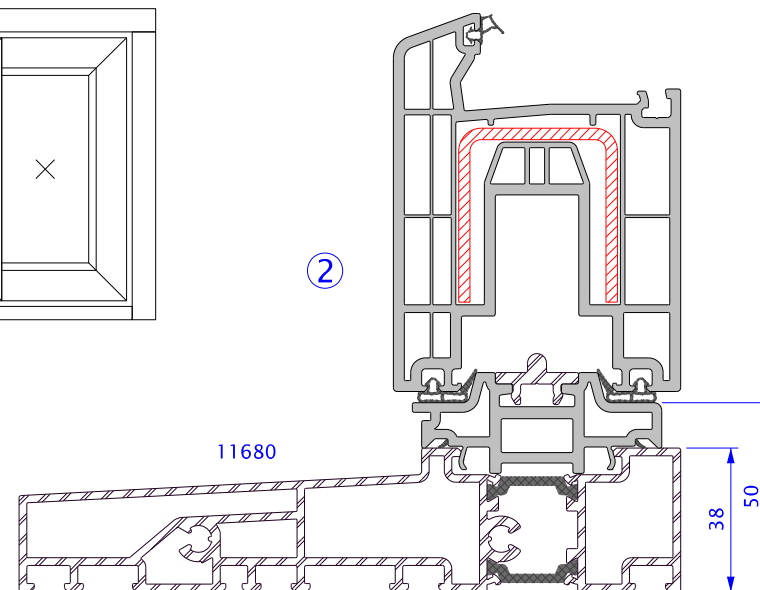
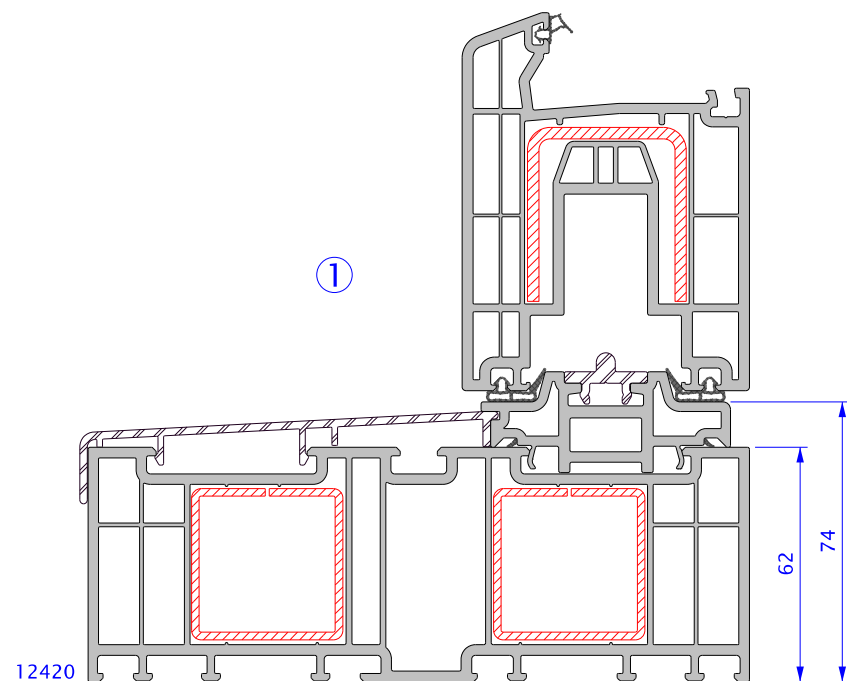
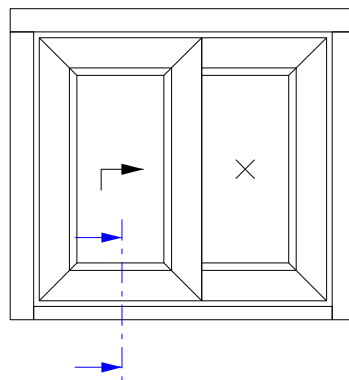

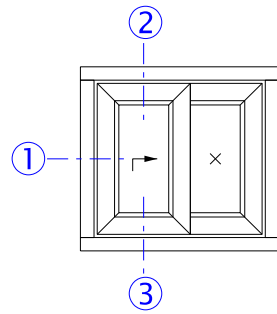
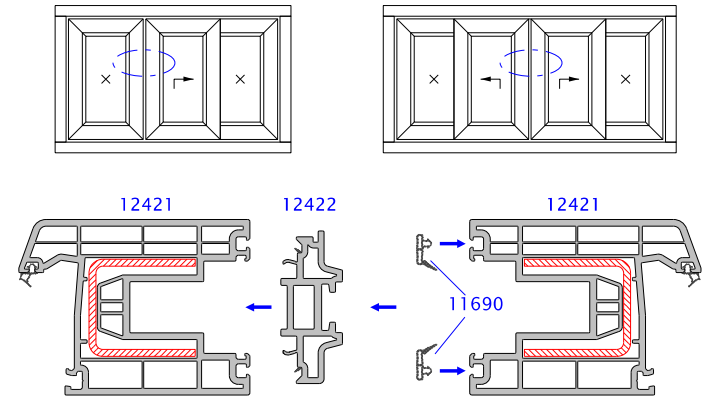
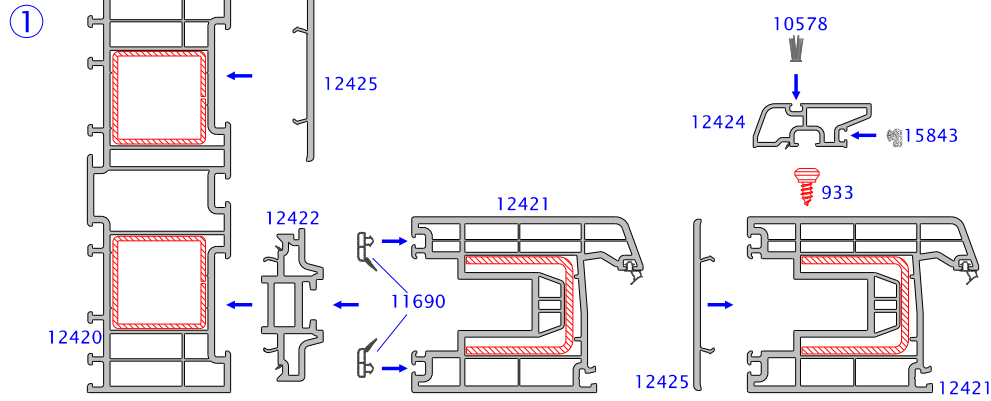

TOP FRAME

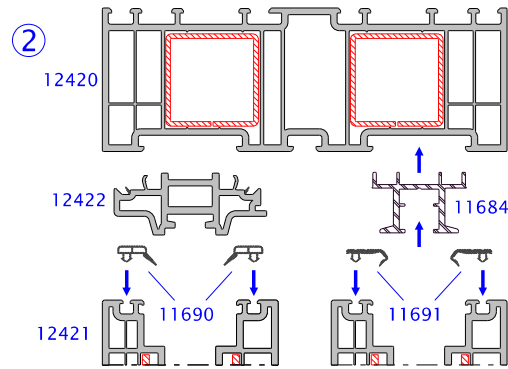

PVC BOTTOM FRAME

3A

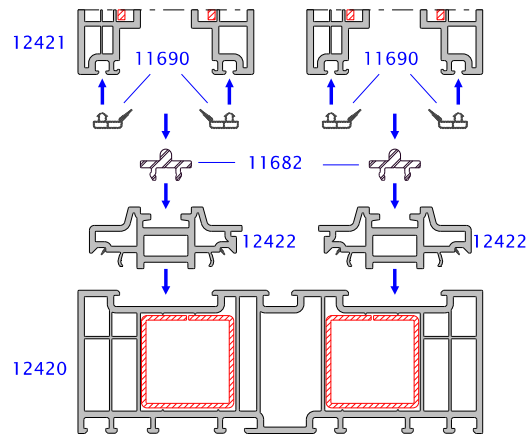

ALUMINIUM THRESHOLD 38 mm

3B

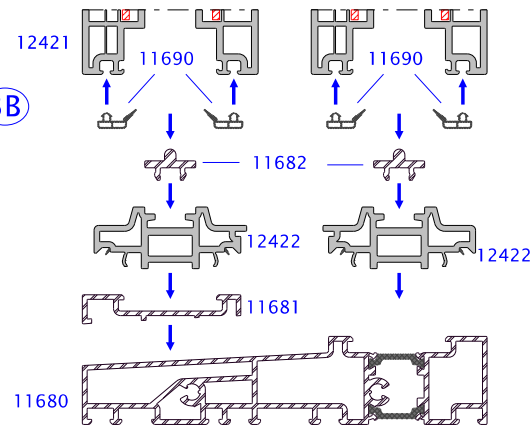

ALUMINIUM THRESHOLD 20 mm

3C

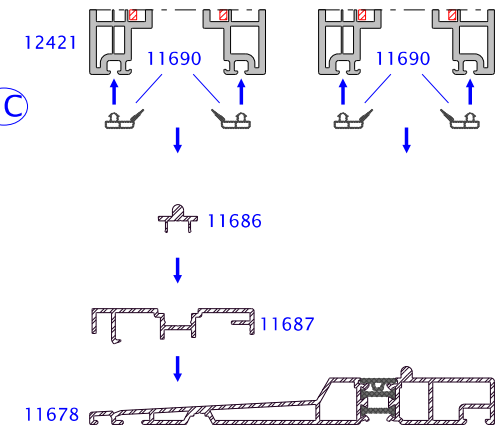

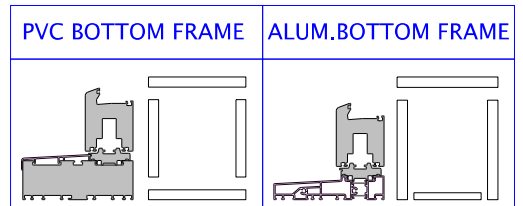
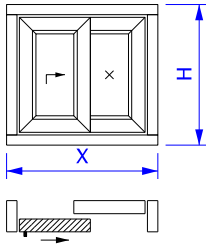

	Product Number	Drawing	Description	PVC BOTTOM FRAME		ALUM. BOTTOM FRAME	
				Pieces	Cutting Size	Pieces	Cutting Size
FRAME	12420		Frame width	2	X	1	X
			Frame Height	2	H-124	2	H-62
	11680		Aluminium Frame Width	-	-	1	X-124
	14357		Reinforcement Width	4	X-5	2	X-5
Reinforcement Height			4	H-330	4	H-167	
SASH	12421		Sash Width	4	(X/2)-21	4	(X/2)-21
			Sash Height	4	H-148	4	H-124
	11685		Sash Alum.Support Width	4	(X/2)-207	4	(X/2)-207
			Sash Alum.Support Height	2	H-334	2	H-310
14655		Sash Reinforcement Height	2	H-334	2	H-310	
LOCKING PROF.	12422		Frame Inner Vertical (90°/45°)	1	H-124	1	H-100
			Frame Inner Bottom Rail Horizontal (45°/90°)	1	X-127	1	X-127
			Frame Outer and Bottom-Top Horizontal	2	(X/2)-12	2	(X/2)-12
			Vertical (1 fixed 1 movable sash)	1	H-148	1	H-124
CLOSING PROFILE	12425		Frame Outer Top Horizontal	1	(X/2)-112	1	(X/2)-112
			Frame Outer Vertical (3°)	1	H-131	1	H-90
			Fixed Sash Vertical (3°)	1	H-131	1	H-90
			Movable Sash Vertical	1	H-154	1	H-130
			Frame Inner Vertical	1	H-124	1	H-100
INTERLOCK	12424		Fixed Sash Vertical	1	H-163	1	H-139
			Movable Sash Vertical	1	H-176	1	H-152
MIDDLE CLOSING	12423		Horizontal Frame	2	(X-124) / 2	2	(X-124) / 2
			Vertical Frame	1	H-162	1	H-138
	12426		Fixed Sash	1	(X/2)-97	1	(X/2)-97
ALUMINIUM	11682		Bottom Rail	1	X-144	1	X-144
	11681		Alum.Frame Horizontal Additional	-	-	1	(X/2)-12
	11683		Horizontal Alum.Cill	1	(X/2)-112	-	-
	11684		Horizontal Top Rail	1	X-147	1	X-147

OPTIONAL

ARCH.	12427		One Side Horizontal (45°/45°)	1	X-79	1	X-79
			One Side Vertical (45°/90°) right-left	2	H-40	2	H-40

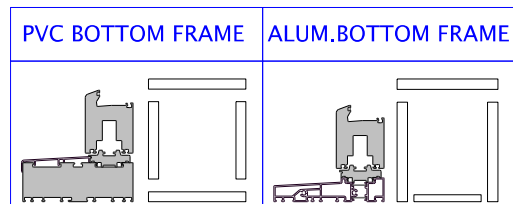
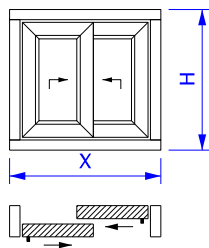

	Product Number	Drawing	Description	Pieces	Cutting Size	Pieces	Cutting Size
FRAME	12420		Frame width	2	X	1	X
			Frame Height	2	H-124	2	H-62
	11680		Aluminium Frame Width	-	-	1	X-124
	14357		Reinforcement Width	4	X-5	2	X-5
Reinforcement Height			4	H-330	4	H-167	
SASH	12421		Sash Width	4	(X/2)-21	4	(X/2)-21
			Sash Height	4	H-148	4	H-124
	11685		Sash Alum.Support Width	4	(X/2)-207	4	(X/2)-207
			Sash Alum.Support Height	2	H-334	2	H-310
14655		Sash Reinforcement Height	2	H-334	2	H-310	
LOCKING PROFILE	12422		Frame Inner Vertical (90°/45°)	2	H-124	2	H-100
			Frame Inner Bottom Rail Horizontal (45°/90°)	2	X-127	2	X-127
CLOSING PROFILE	12425		Frame Outer Vertical (3°)	2	H-124	2	H-100
			Frame Inner Vertical	2	H-154	2	H-130
INTER-LOCK	12424		Sash Inner Vertical	2	H-176	2	H-152
MIDDLE CLOSING	12423		Horizontal Frame	2	(X-124) / 2	2	(X-124) / 2
	12426		In front of Sash	1	(X/2)-97	1	(X/2)-97
			In front of Sash	1	(X/2)-112	1	(X/2)-112
ALUMINIUM	11682		Bottom Rail	2	X-144	1	X-144
	11681		Alum.Frame Vertical Additional	-	-	1	X-124
	11684		Horizontal Top Rail	2	X-147	1	X-147

OPTIONAL

ARCH.	12427		One Side Horizontal (45°/45°)	1	X-79	1	X-79
			One Side Vertical (45°/90°) right-left	2	H-40	2	H-40

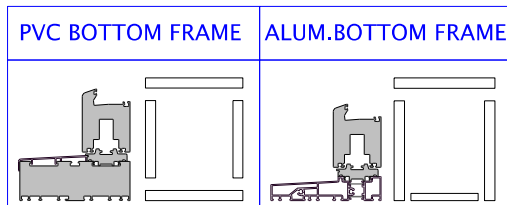
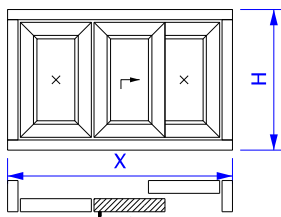

	Product Number	Drawing	Description	Pieces	Cutting Size	Pieces	Cutting Size
FRAME	12420		Frame width	2	X	1	X
			Frame Height	2	H-124	2	H-62
	11680		Aluminium Frame Width	-	-	1	X-124
	14357		Reinforcement Width	4	X-5	2	X-5
			Reinforcement Height	4	H-330	4	H-167
SASH	12421		Sash Width	6	(X/3)-17	6	(X/3)-17
			Sash Height	6	H-148	6	H-124
	11685		Sash Alum.Support Width	6	(X/3)-203	6	(X/3)-203
			Sash Alum.Support Height	2	H-334	2	H-310
14655		Sash Reinforcement Height	4	H-334	2	H-310	
LOCKING PROF.	12422		Frame Inner Vertical (90°/45°)	1	H-124	1	H-100
			Frame Inner Bottom Rail Horizontal (45°/90°)	1	2X/3-119	1	2X/3-119
			Frame Outer and Bottom-Top Horizontal	4	(X/3)-8	4	(X/3)-8
			Vertical (1 fixed 1 movable sash)	2	H-148	2	H-124
CLOSING PROFILE	12425		Frame Outer Top Horizontal	1	2X/3-116	1	2X/3-116
			Frame Outer Vertical (3°)	1	H-131	1	H-94
			Outer Vertical Fixed Sash (3°)	1	H-131	1	H-90
			Movable Sash Vertical	1	H-154	1	H-130
			Frame Inner Vertical	1	H-124	1	H-100
INTERLOCK	12424		Fixed Sash Vertical	1	H-163	1	H-139
			Movable Sash Vertical	1	H-176	1	H-152
MIDDLE CLOSING	12423		Horizontal Frame	1	(X/3)-58	1	(X/3)-58
			Horizontal Frame	1	(2X/3)-66	1	(2X/3)-66
			Vertical Frame	1	H-162	1	H-138
12426		Fixed Sash	1	(X/3)-93	1	(X/3)-93	
ALUMINIUM	11682		Bottom Rail	1	2X/3-136	1	2X/3-136
	11681		Alum.Frame Horizontal Additional	-	-	1	(X/3)-8
	11683		Horizontal Alum.Cill	1	2X/3-116	-	-
	11684		Horizontal Top Rail	1	2X/3-119	1	2X/3-119
OPTIONAL							
ARCH.	12427		One Side Horizontal (45°/45°)	1	X-79	1	X-79
			One Side Vertical (45°/90°) right-left	2	H-40	2	H-40

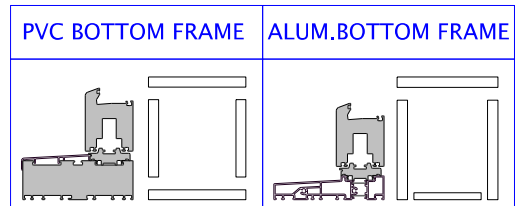
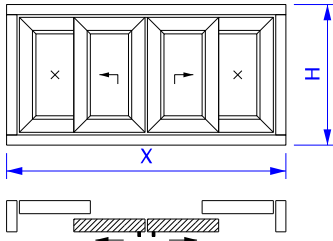

	Product Number	Drawing	Description	Pieces	Cutting Size	Pieces	Cutting Size
FRAME	12420		Frame width	2	X	1	X
			Frame Height	2	H-124	2	H-62
	11680		Aluminium Frame Width	-	-	1	X-124
	14357		Reinforcement Width	4	X-5	2	X-5
Reinforcement Height			4	H-330	4	H-167	
SASH	12421		Sash Width	8	$(X+55)/4$	8	$(X+55)/4$
			Sash Height	8	H-148	8	H-124
	11685		Sash Alum.Support Width	8	$(X-689)/4$	8	$(X-689)/4$
			Sash Alum.Support Height	2	H-334	2	H-310
14655		Sash Reinforcement Height	6	H-334	6	H-310	
		12422		Frontal Closing (90°)	1	H-154	1
Frame Inner Rail Horizontal(90°)	1			X-130	1	X-130	
Frame Outer & Bottom - Top Horizontal	4			$(X+91)/4$	4	$(X+91)/4$	
Frame Outer Vertical (45°/90°)	2			H-148	2	H-124	
CLOSING PROFILE	12425		Frame Outer Top Horizontal	1	X/2-169	1	X/2-169
			Frame Outer Vertical (3°)	2	H-131	2	H-90
			Inner Sash Vertical	2	H-154	2	H-130
			Frame Inner Vertical	2	H-124	2	H-100
INTERLOCK	12424		Fixed Sash Vertical	2	H-163	2	H-139
			Movable Sash Vertical	2	H-176	2	H-152
MIDDLE CLOSING	12423		Horizontal Frame	2	$(X/4)+23$	2	$(X/4)+23$
			Horizontal Frame	1	$(X/2)-46$	1	$(X/2)-46$
ADD. LOCK.	12426		Fixed Sash	2	X/4-62	2	X/4-62
ALUMINIUM	11682		Bottom Rail	1	X-130	1	X-130
	11681		Alum.Frame Horizontal Additional	-	-	2	$(X+91)/4$
	11683		Horizontal Alum.Cill	1	X/2-169	-	-
	11684		Horizontal Top Rail	1	X-130	1	X-130

OPTIONAL

ARCH.	12427		One Side Horizontal (45°/45°)	1	X-79	1	X-79
			One Side Vertical (45°/90°) right-left	2	H-40	2	H-40

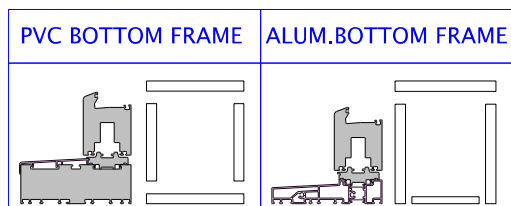
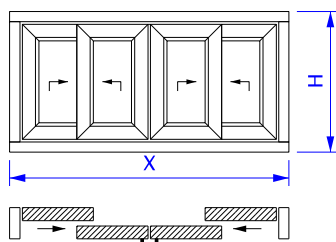

	Product Number	Drawing	Description	Pieces	Cutting Size	Pieces	Cutting Size
FRAME	12420		Frame width	2	X	1	X
			Frame Height	2	H-124	2	H-62
	11680		Aluminium Frame Width	-	-	1	H-124
	14357		Reinforcement Width	4	X-5	2	X-5
Reinforcement Height			4	H-330	4	H-167	
SASH	12421		Sash Width	8	$(X+55) / 4$	8	$(X+55) / 4$
			Sash Height	8	H-148	8	H-124
	11685		Sash Alum.Support Width	8	$(X-689) / 4$	8	$(X-689) / 4$
			Sash Alum.Support Height	2	H-334	2	H-334
14655		Sash Reinforcement Height	6	H-334	6	H-310	
LOCKING PROF.	12422		Frontal Closing (90°)	1	H-154	1	H-130
			Frame Inner Rail Horizontal(90°)	1	X-130	1	X-130
			Frame Outer & Bottom Horizontal (45°/45°)	1	X-124	1	X-124
			Frame Outer Vertical (45°/90°)	2	H-124	2	H-100
CLOSING PROFILE	12425		Frame Vertical	4	H-154	4	H-130
			Frame Inner Vertical	2	H-124	2	H-100
INTER-LOCK	12424		Sash Inner-Outer Vertical	4	H-176	4	H-152
MIDDLE CLOSING	12423		Frame Horizontal	2	$(X/4)+23$	2	$(X/4)+23$
			Frame Horizontal	1	$(X/2)-46$	1	$(X/2)-46$
ADD. LOCK.	12426		In front of Sash	2	X/4-62	2	X/4-62
			In front of Sash	1	X/2-169	1	X/2-169
ALUMINIUM	11682		Rail	1	X-130	1	X-130
			Rail	1	X-158	1	X-158
	11681		Alum.Frame Vertical Additional	-	-	1	X-124
	11684		Horizontal Top Rail	2	X-130	2	X-130

OPTIONAL

ARCH.	12427		One Side Horizontal (45°/45°)	1	X-79	1	X-79
			One Side Vertical (45°/90°) right-left	2	H-40	2	H-40

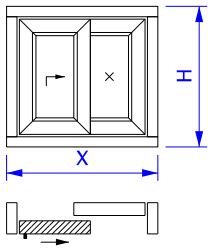

ALUM. BOTTOM FRAME

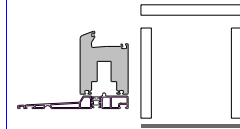

	Product Number	Drawing	Description	Pieces	Cutting Size
FRAME	12420		Frame width	1	X
			Frame Height	2	H-82
	11678		Aluminium Frame Width	1	X
			Reinforcement Width	2	X-5
SASH	12421		Sash Width	4	(X/2)-21
			Sash Height	4	H-94
	11685		Sash Alum.Support Width	4	(X/2)-207
			Sash Alum.Support Height	2	H-292
14655		Sash Reinforcement Height	2	H-292	
LOCKING PROFILES	12422		Frame Inner Vertical	1	H-82
			Frame Outer Top Horizontal	1	(X/2)-12
			Outer Vertical Fixed	1	H-94
CLOSING PROFILE	12425		Frame Outer Top Horizontal	1	(X/2)-112
			Frame Outer Vertical (3°)	1	H-67
			Fixed Sash Vertical (3°)	1	H-67
			Movable Sash Vertical	1	H-100
			Frame Inner Vertical	1	H-82
INTERLOCK	12424		Fixed Sash Vertical	1	H-79
			Movable Sash Vertical	1	H-122
MID. CLOSING	12423		Horizontal Frame	2	(X-124) / 2
			Vertical Frame	1	H-102
ALM.	11687		Alum.Frame Horizontal Additional	1	(X/2)-12
	11684		Horizontal top Rail	1	X-147

OPTIONAL

ARCH.	12427		One Side Horizontal (45°/45°)	1	X-79
			One Side Vertical (45°/90°) right-left	2	H-40

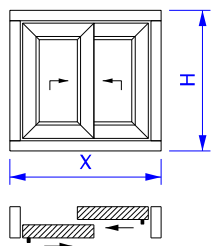

ALUM.BOTTOM FRAME

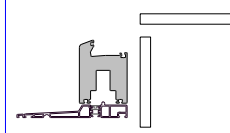

	Product Number	Drawing	Description	Pieces	Cutting Size
FRAME	12420		Frame width	1	X
			Frame Height	2	H-82
	11678		Aluminium Frame Width	1	X
			Reinforcement Width	2	X-5
14357		Reinforcement Height	4	H-287	
SASH	12421		Sash Width	4	(X/2)-21
			Sash Height	4	H-94
	11685		Sash Alum.Support Width	4	(X/2)-207
			Sash Alum.Support Height	2	H-292
14655		Sash Reinforcement Height	2	H-292	
LOCKING PROFILES	12422		Frame Inner Vertical	2	H-82
INTER CLOSING PROFILE	12425		Frame Inner Vertical	2	H-82
			Inner Sash Outer Vertical	2	H-100
INTER LOCK	12424		Frame Inner Vertical	2	H-122
MID. CLOSING	12423		Horizontal Frame	2	(X-124) / 2
ALUMINIUM	11686		Bottom Rail	1	X-144
	11687		Alum.Frame Horizontal Additional	1	X-124
	11684		Horizontal top Rail	2	X-147

OPTIONAL

ARCH.	12427		One Side Horizontal (45°/45°)	1	X-79
			One Side Vertical (45°/90°) right-left	2	H-40

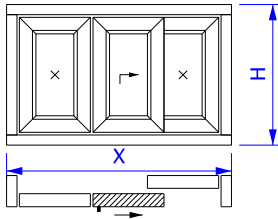

ALUM.BOTTOM FRAME

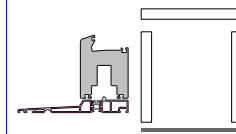

	Product Number	Drawing	Description	Pieces	Cutting Size
FRAME	12420		Frame width	1	X
			Frame Height	2	H-82
	11678		Aluminium Frame Width	1	X
	14357		Reinforcement Width	2	X-5
Reinforcement Height			4	H-287	
SASH	12421		Sash Width	6	(X/3)-17
			Sash Height	6	H-94
	11685		Sash Alum.Support Width	6	(X/3)-203
			Sash Alum.Support Height	2	H-292
14655		Sash Reinforcement Height	2	H-292	
LOCKING PROFILES	12422		Inner Sash Outer Vertical	1	H-94
			Frame Outer & Inner Top Horizontal	2	(X/3)-8
			Inner Vertical (1 Fixed 1 Movable Sash)	1	H-82
CLOSING PROFILE	12425		Frame Outer Top Horizontal	1	2X/3-116
			Frame Outer Vertical (3°)	1	H-67
			Fixed Sash Outer Vertical (3°)	1	H-67
			Movable Inner Sash Vertical	1	H-100
			Frame Inner Vertical	1	H-82
INTERLOCK	12424		Fixed Sash Vertical	1	H-79
			Movable Sash Vertical	1	H-122
MID. CLOSING	12423		Horizontal Frame	1	(X/3)-58
			Horizontal Frame	1	(2X/3)-66
			Vertical Frame	1	H-102
ALUMINIUM	11686		Bottom Rail	1	2X/3-136
	11687		Alum.Frame Horizontal Additional	1	(X/3)-8
	11684		Horizontal top Rail	1	2X/3-119

OPTIONAL

ARCH.	12427		One Side Horizontal (45°/45°)	1	X-79
			One Side Vertical (45°/90°) right-left	2	H-40

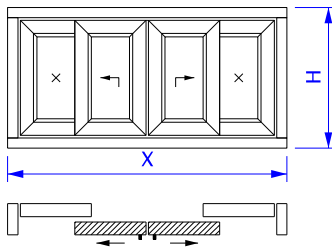

ALUM.BOTTOM FRAME

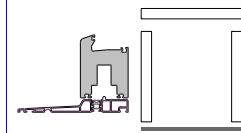

	Product Number	Drawing	Description	Pieces	Cutting Size
FRAME	12420		Frame width	1	X
			Frame Height	2	H-82
	11678		Aluminium Frame Width	1	X
	14357		Reinforcement Width	2	X-5
Reinforcement Height			4	H-287	
SASH	12421		Sash Width	8	$(X+55)/4$
			Sash Height	8	H-94
	11685		Sash Alum.Support Width	8	$(X-689)/4$
			Sash Alum.Support Height	2	H-292
14655		Sash Reinforcement Height	6	H-292	
LOCKING PROFILES	12422		Frontal Closing (90°)	1	H-100
			Frame Outer Top Horizontal	2	$(X+91)/4$
			Frame Outer Vertical (45°/90°)	2	H-94
CLOSING PROFILE	12425		Frame Outer Top Horizontal	1	$X/2-169$
			Outer Vertical Sash (3°)	2	H-67
			Inner Sash Vertical	2	H-100
			Frame Inner Vertical	2	H-82
INTERLOCK	12424		Fixed Sash Vertical	2	H-79
			Movable Sash Vertical	2	H-122
MID. CLOSING	12423		Frame Horizontal	2	$(X/4)+23$
			Frame Horizontal	1	$(X/2)-46$
ALUMINIUM	11686		Bottom Rail	1	X-130
	11687		Alum.Frame Horizontal Additional	2	$(X+91)/4$
	11684		Horizontal Top Rail	1	X-130

OPTIONAL

ARCH.	12427		One Side Horizontal (45°/45°)	1	X-79
			One Side Vertical (45°/90°) right-left	2	H-40

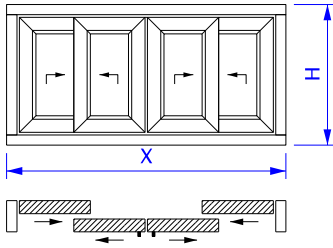

ALUM.BOTTOM FRAME

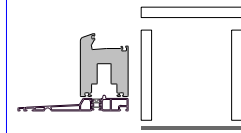

	Product Number	Drawing	Description	Pieces	Cutting Size
FRAME	12420		Frame width	1	X
			Frame Height	2	H-82
	11678		Aluminium Frame Width	1	X
	14357		Reinforcement Width	2	X-5
Reinforcement Height			4	H-287	
SASH	12421		Sash Width	8	$(X+55) / 4$
			Sash Height	8	H-94
	11685		Sash Alum.Support Width	8	$(X-689) / 4$
			Sash Alum.Support Height	2	H-292
14655		Sash Reinforcement Height	6	H-292	
LOCKING PROFILES	12422		Frontal Closing (90°)	1	H-100
			Frame Outer Vertical (45°/90°)	2	H-82
CLOSING PROFILE	12425		Sash Vertical	4	H-100
			Frame Inner Vertical	2	H-82
INTER LOCK	12424		Inner Sash-Outer Vertical	4	H-122
MID. CLOSING	12423		Frame Horizontal	2	$(X/4)+23$
			Frame Horizontal	1	$(X/2)-46$
ALUMINIUM	11686		Bottom Rail	1	X-130
	11687		Alum.Frame Horizontal Additional	1	X-124
	11684		Horizontal Top Rail	2	X-130

OPTIONAL

ARCH.	12427		One Side Horizontal (45°/45°)	1	X-79
			One Side Vertical (45°/90°) right-left	2	H-40

1. TOP and BOTTOM HORIZONTAL FRAME PROFILE :

* The reinforcement (14357) is cut in two pieces and each piece must be shorter than frame width about 5 mm

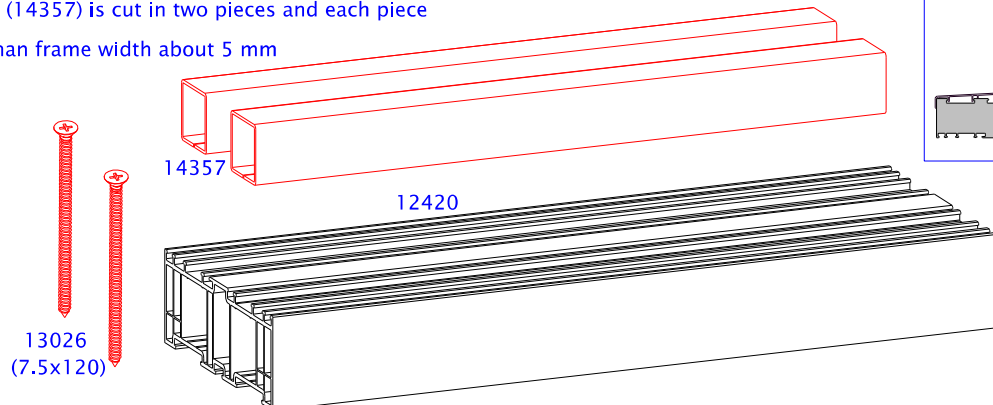

PVC BOTTOM FRAME

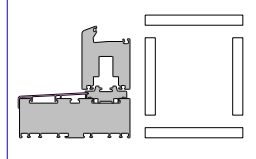

2. VERTICAL FRAME PROFILES :

* Two pieces of reinforcement (14357) is cut by decreasing 330 mm from frame vertical length

* Alum. Frame Support (13046) is fixed top and bottom sides of the box by screws

* Frame Filler (11694) and Frame Isolation (11692) are mounted on frame as seen in picture left

* Frame is mounted with 7.5x120 mounting screw

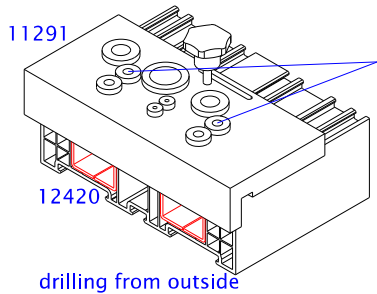
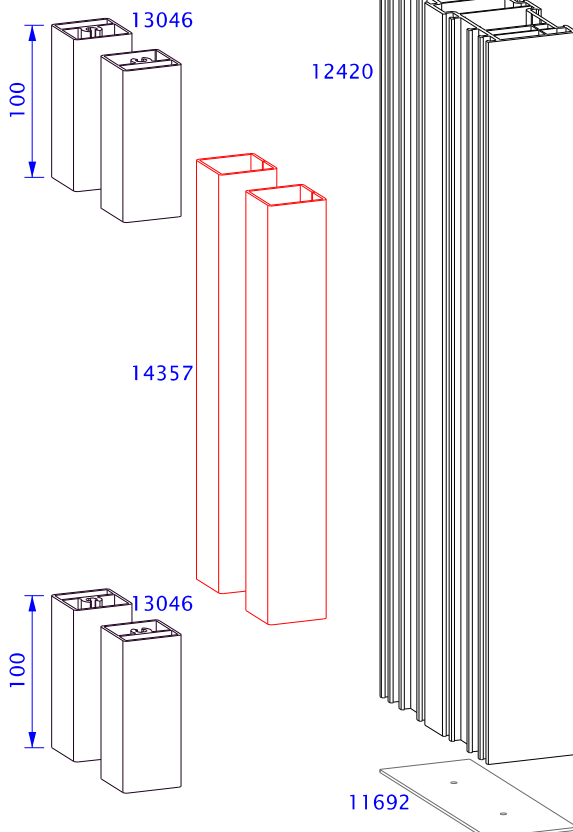

For connecting PVC frame (12420) to PVC frame (12420) these holes that are places on aparey will be used.
Holes must drilled with Ø 6,5mm drill bit.

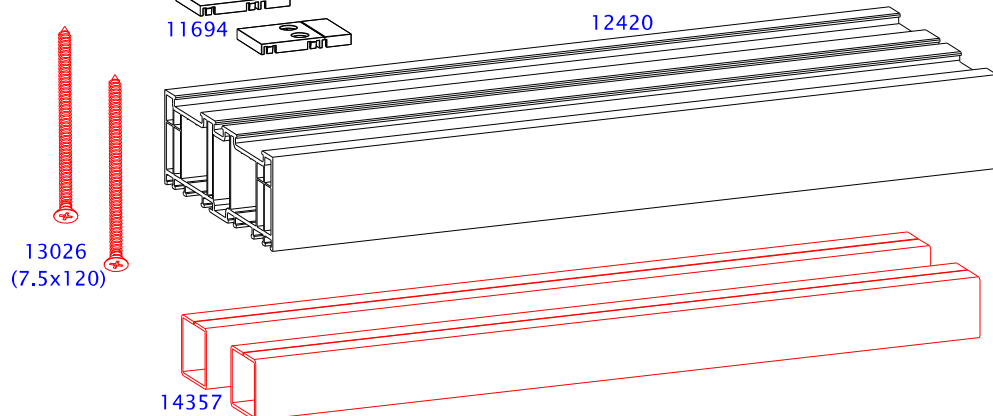
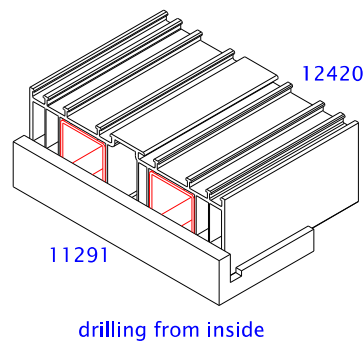
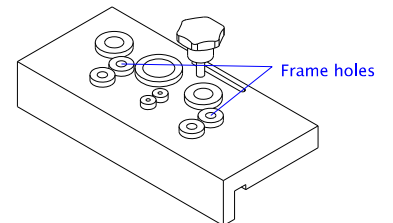

1. TOP and BOTTOM HORIZONTAL FRAME :

* The reinforcement (14357) is cut in two pieces and each piece must be shorter than frame width about 5 mm

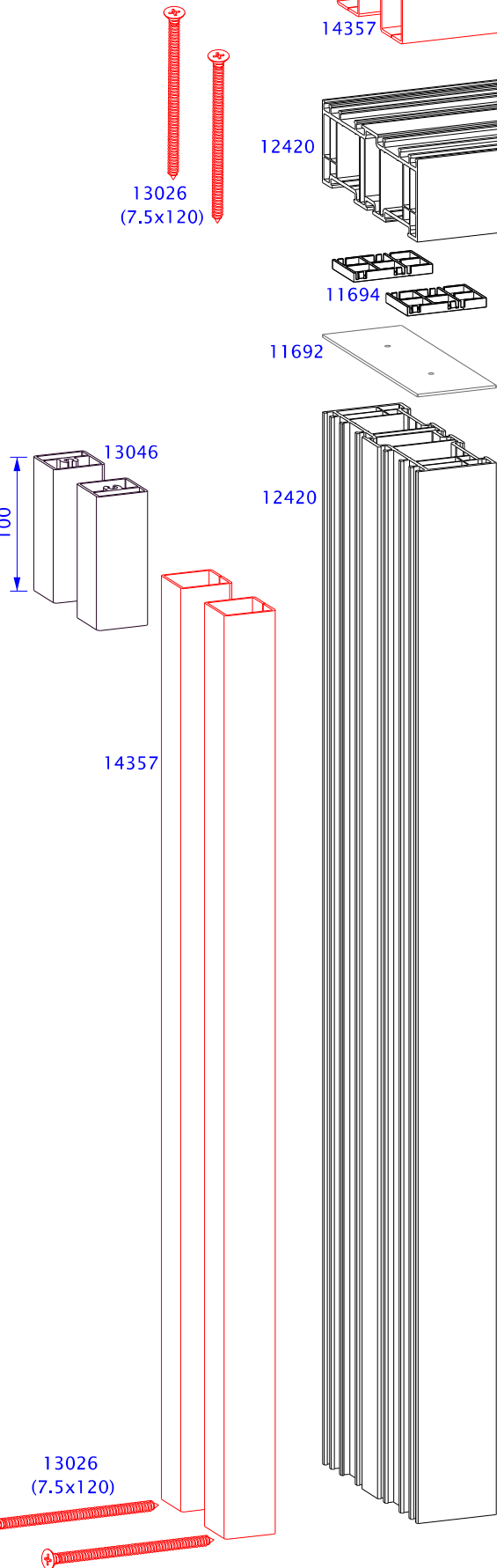

ALUM. BOTTOM FRAME

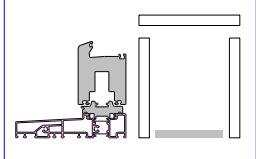

2. VERTICAL FRAME PROFILES :

- * Two pieces of reinforcement (14357) is cut by decreased 330 mm from frame vertical length
- * Alum. Frame Support (13046) is fixed top and bottom sides of the box by screws
- * Frame Filler (11694) and Frame Isolation (11692) are mounted on frame as seen in picture left
- * Frame is mounted with 7.5x120 mounting screw.

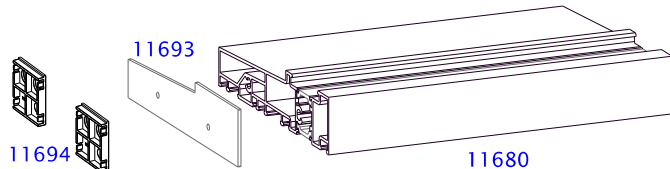
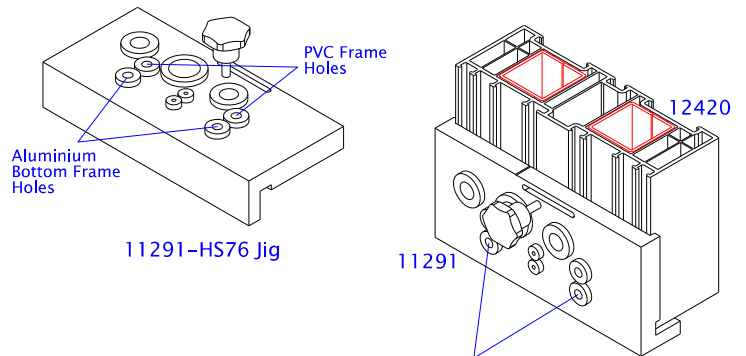
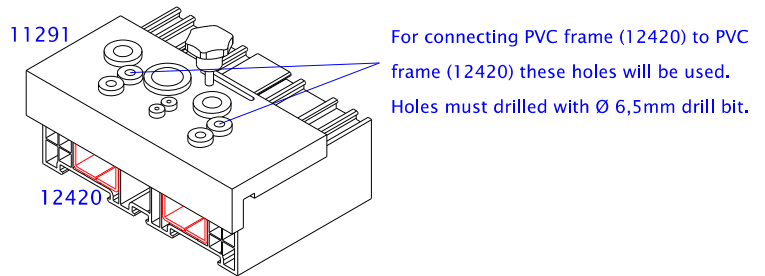

1. TOP and BOTTOM HORIZONTAL FRAME :

* The reinforcement (14357) is cut in two pieces and each piece must be shorter than frame width about 5 mm

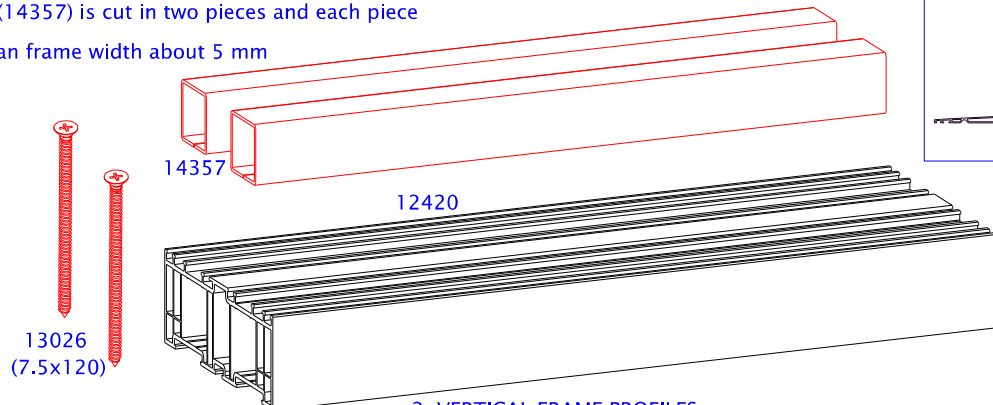

PVC BOTTOM FRAME

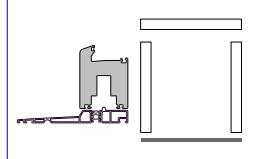

2. VERTICAL FRAME PROFILES :

* Two pieces of reinforcement (14357) is cut by decreased 287 mm from frame vertical length
 * Alum. Frame Support (13046) is fixed top and bottom sides of the box by screws
 * Between Alm. Frame and Vertical Frame, 11699 Filler Piece is inserted.
 The system is screwed by 7.5x120 installation screw

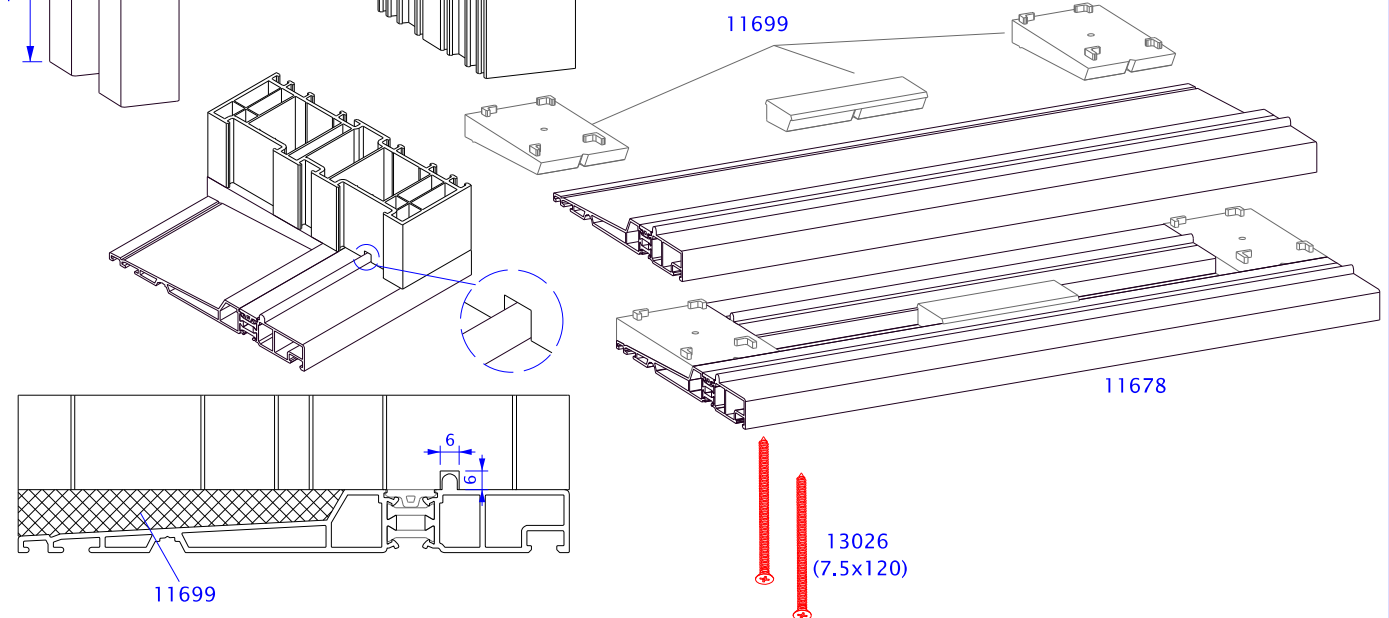
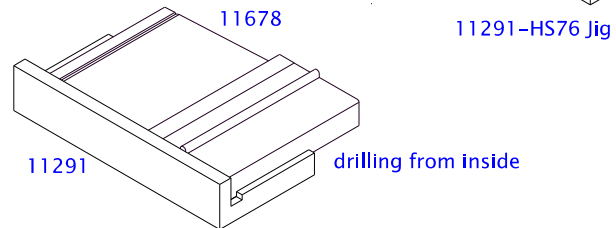
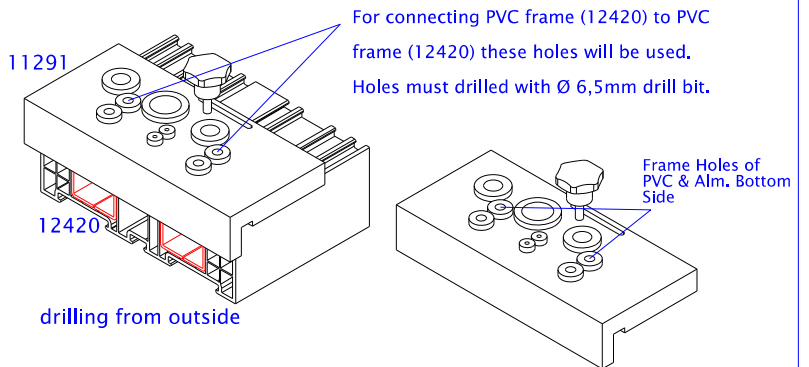
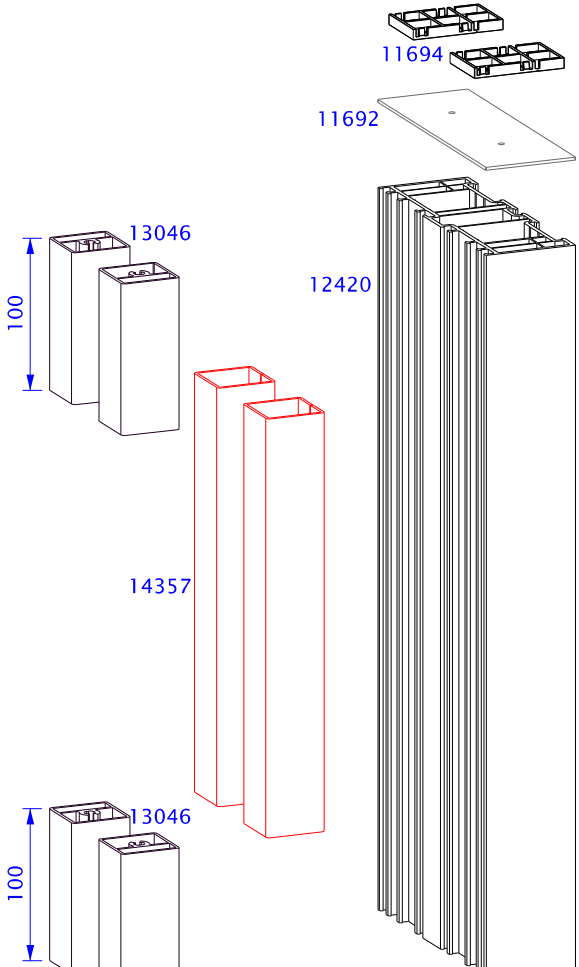

11689-HS76 Mid. Seal must be used in bottom frame applications.

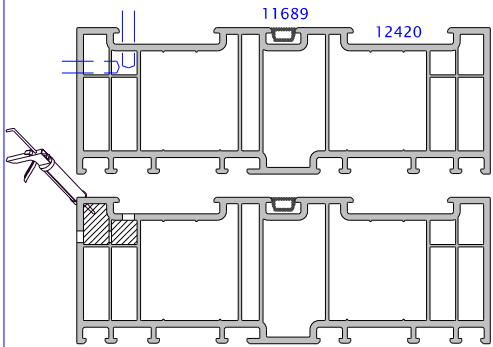

Not : Frame must be siliconed both sides in PVC bottom frame applications.

After the water drainage has been drilled, 12422 and 11683 (If the PVC bottom frame cover application will be used) profiles are milled to accelerate water discharge from the frame. It is given in the drawings.

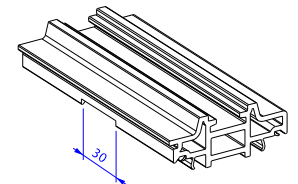
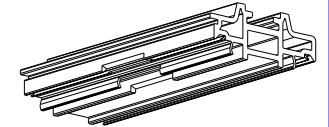
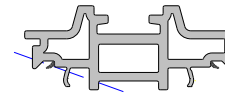
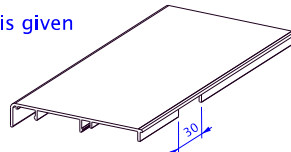
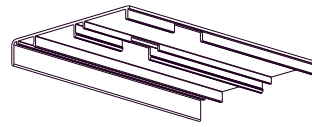

OUTSIDE

FRAME TOP VIEW

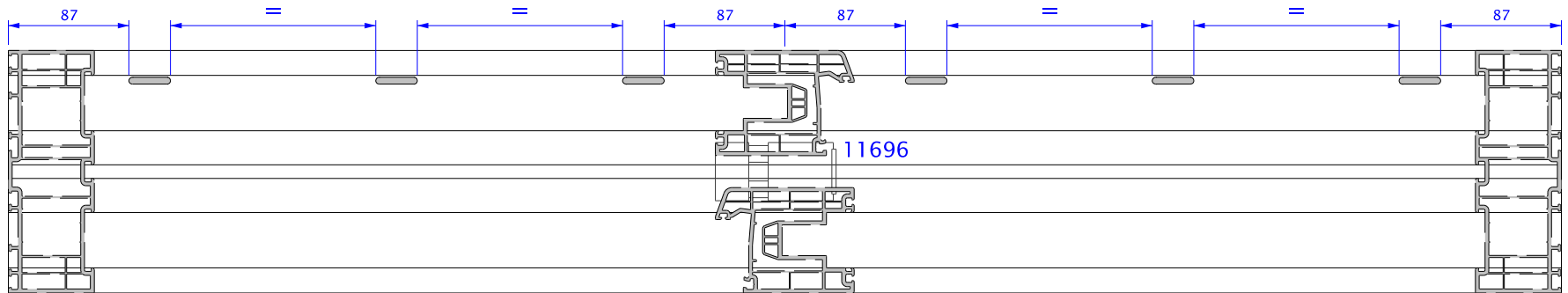

INSIDE

FRAME EXTERNAL VIEW

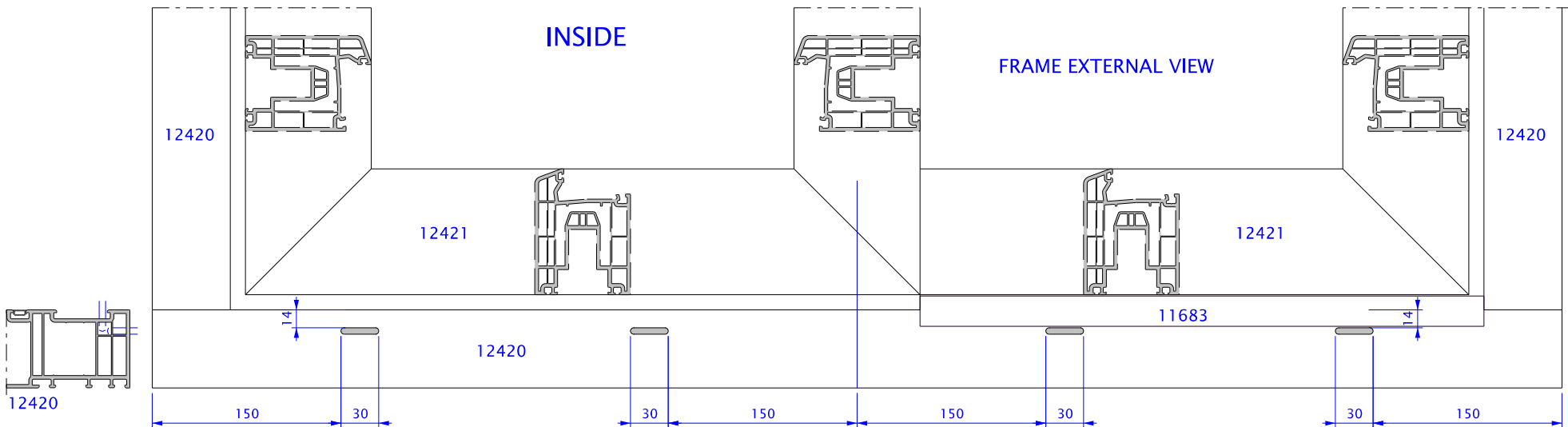

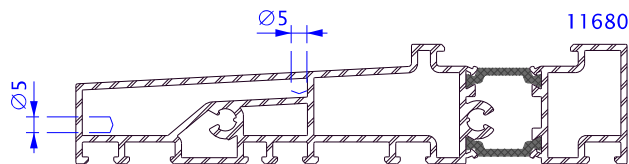

After the water drainage has been drilled, 12422 and 11680 (If the PVC bottom frame cover application will be used) profiles are milled to accelerate water discharge from the frame. It is given in the drawings

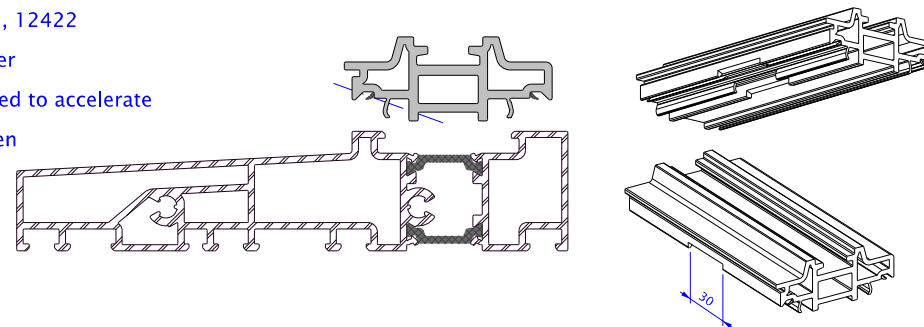

FRAME TOP VIEW

OUTSIDE

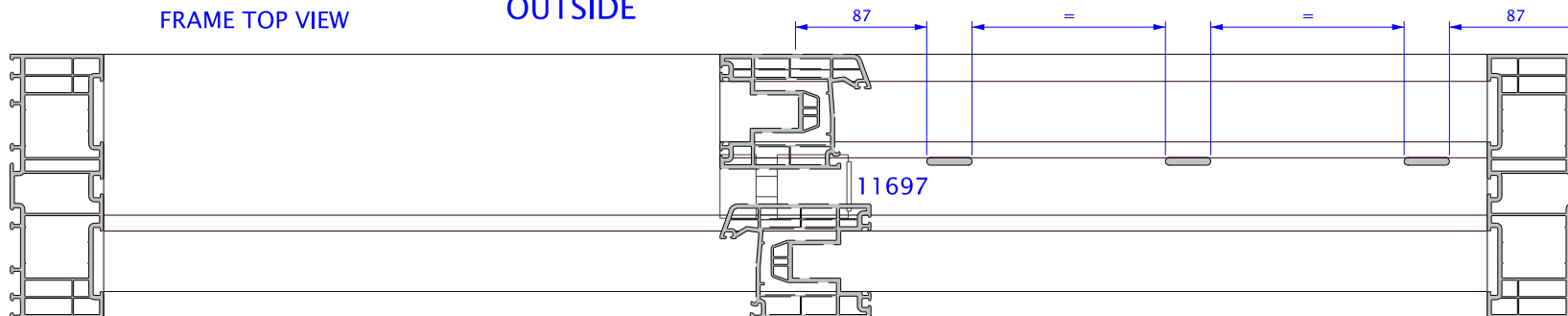

INSIDE

FRAME EXTERNAL VIEW

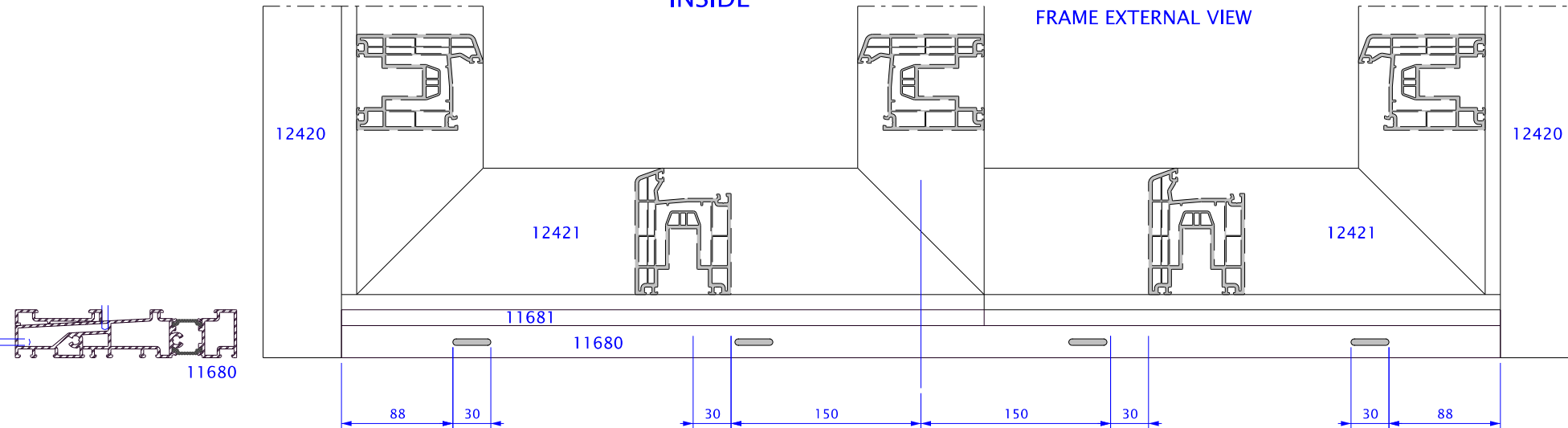

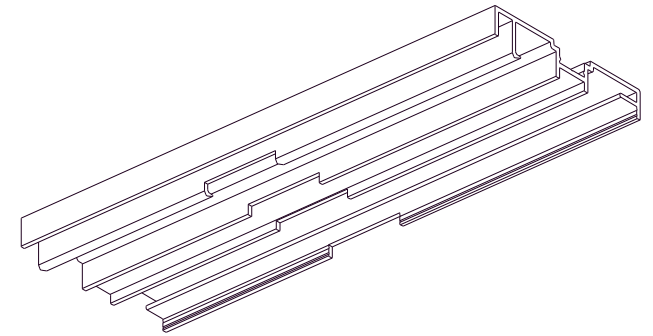
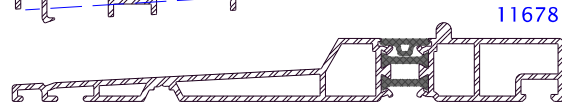
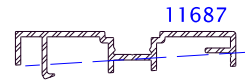
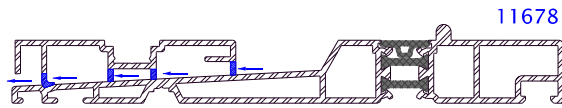

FRAME TOP VIEW

OUTSIDE

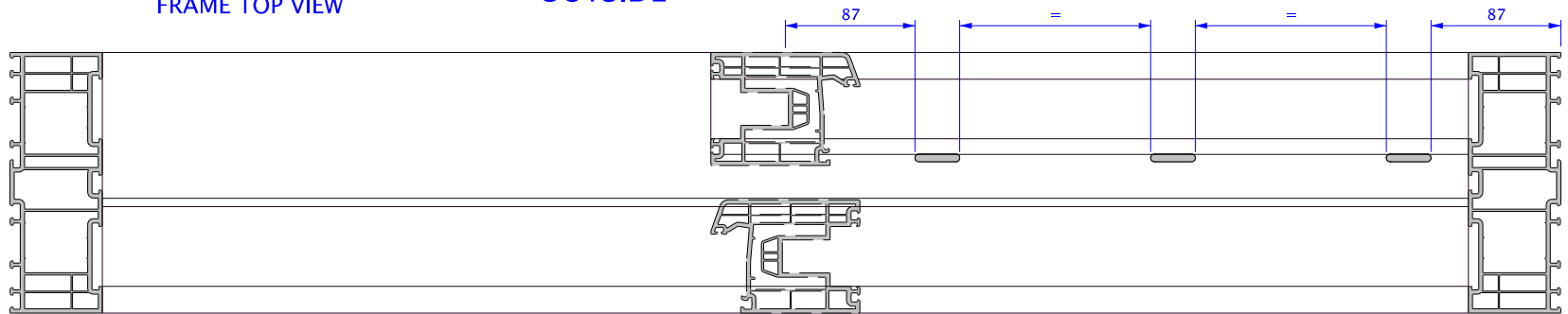

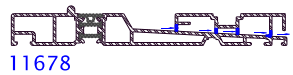
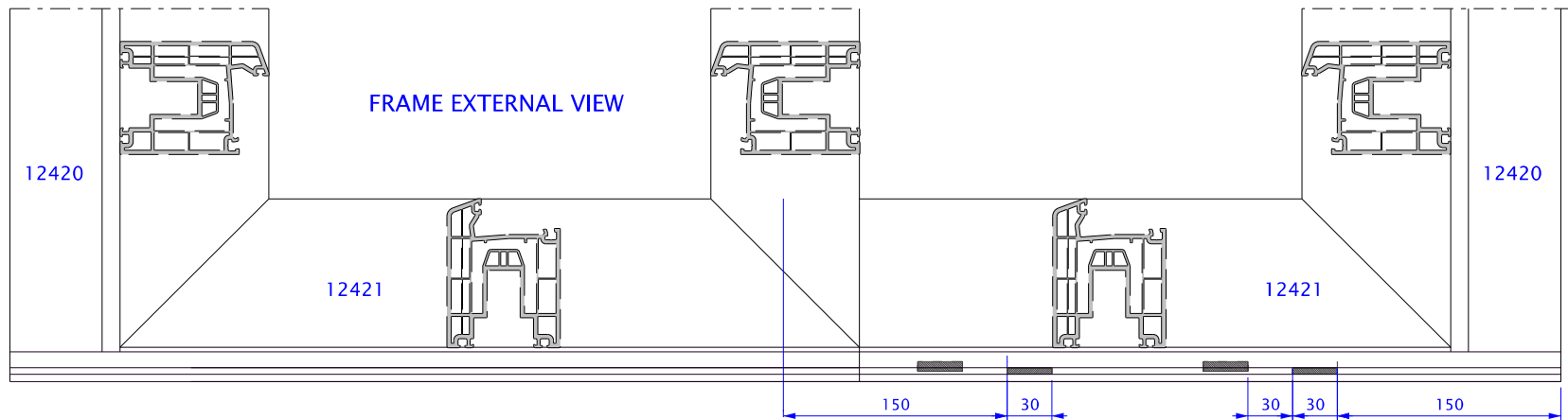

INSIDE

FRAME EXTERNAL VIEW

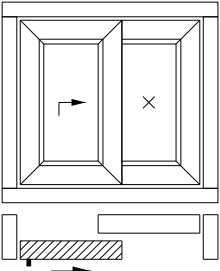
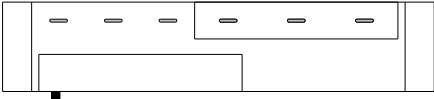
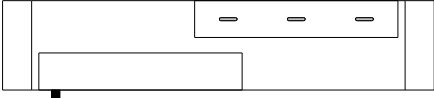
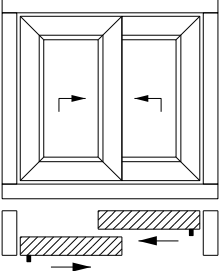
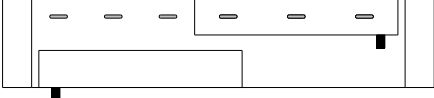
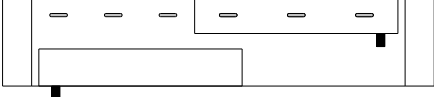
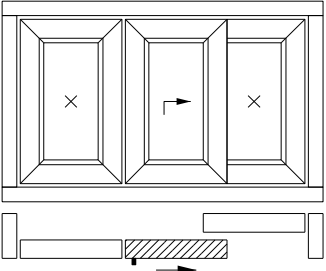

11678

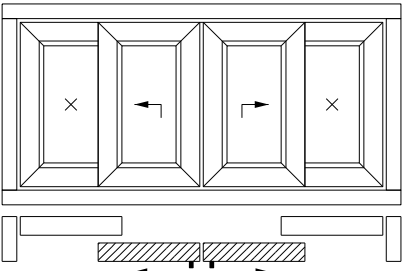
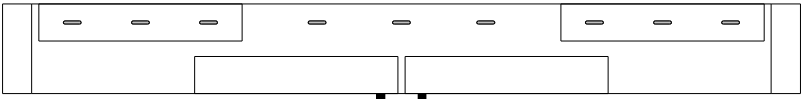
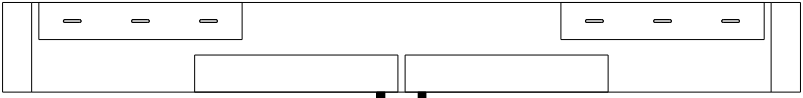
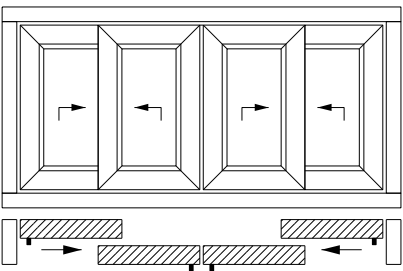
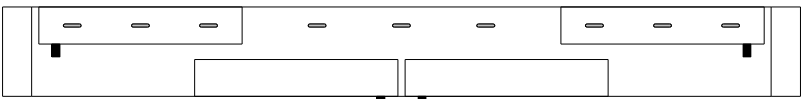
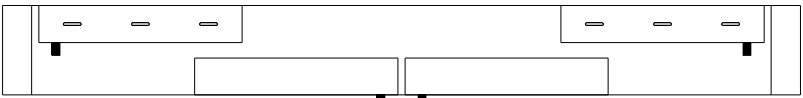
OPENING TYPES	DRAINAGE SCHEMAS TOP VIEW)
<p>A SCHEMA</p> 	<p>12420 - PVC BOTTOM FRAME</p>  <p>11680 - ALUMINIUM BOTTOM FRAME</p> 
<p>D SCHEMA</p> 	<p>12420 - PVC BOTTOM FRAME</p>  <p>11680 - ALUMINIUM BOTTOM FRAME</p> 
<p>G3 SCHEMA</p> 	<p>12420 - PVC BOTTOM FRAME</p>  <p>11680 - ALUMINIUM BOTTOM FRAME</p> 
<p>C SCHEMA</p> 	<p>12420 - PVC BOTTOM FRAME</p>  <p>11680 - ALUMINIUM BOTTOM FRAME</p> 
<p>F SCHEMA</p> 	<p>12420 - PVC BOTTOM FRAME</p>  <p>11680 - ALUMINIUM BOTTOM FRAME</p> 

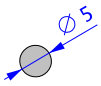

Air hole / decompression

(The air holes can be drilled as drainage holes on sash inner side as shown)

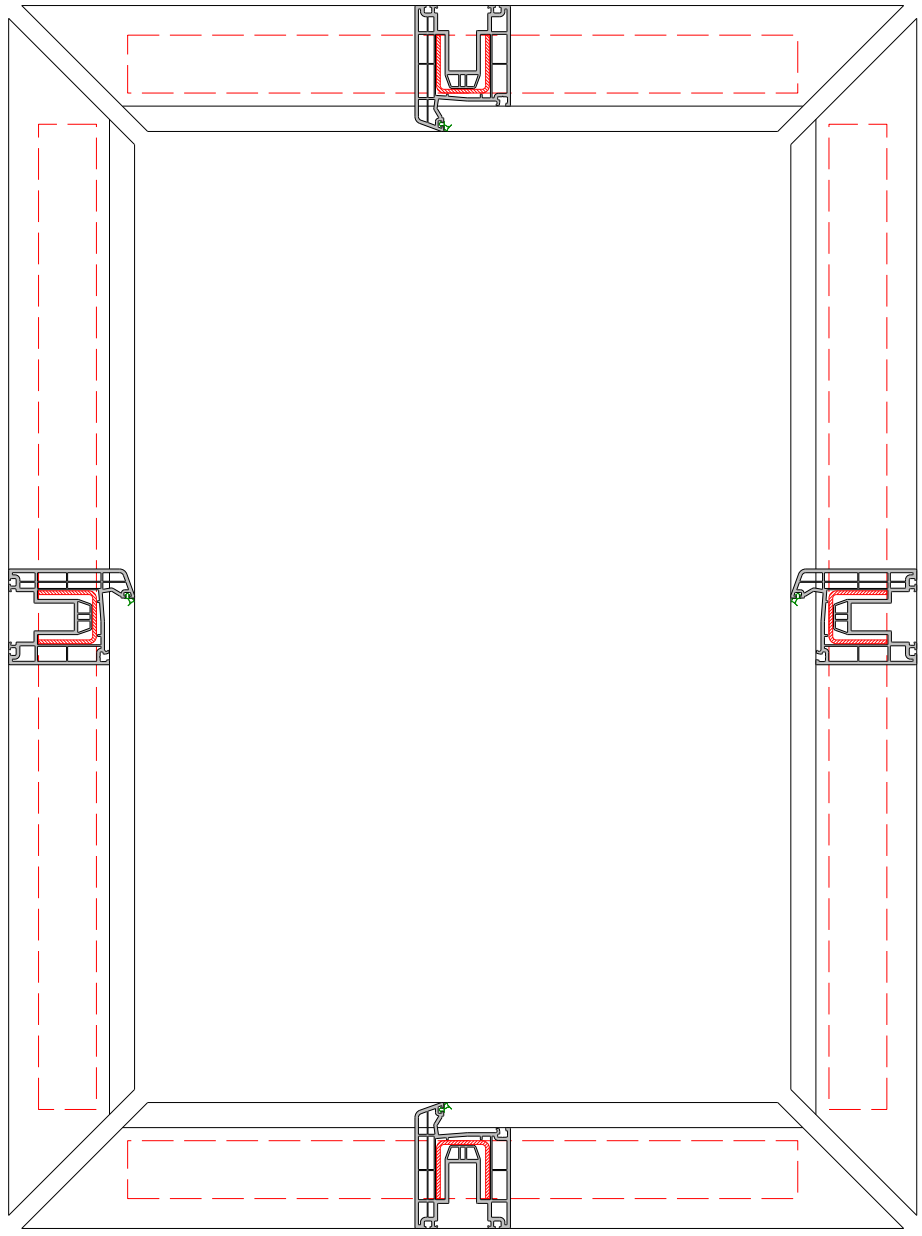
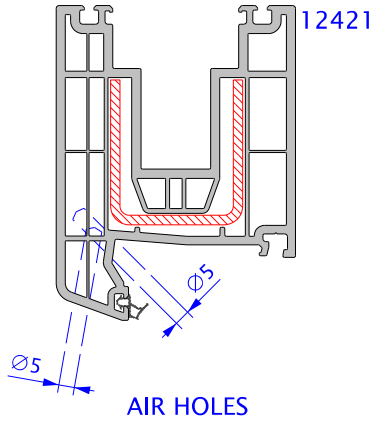

DRAINAGE

1. version

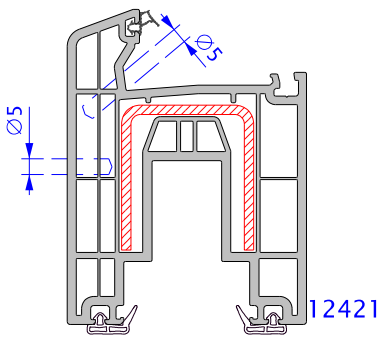

2. version

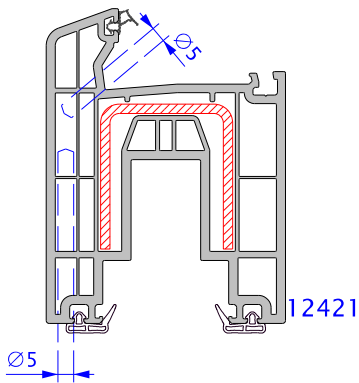

drainage hole

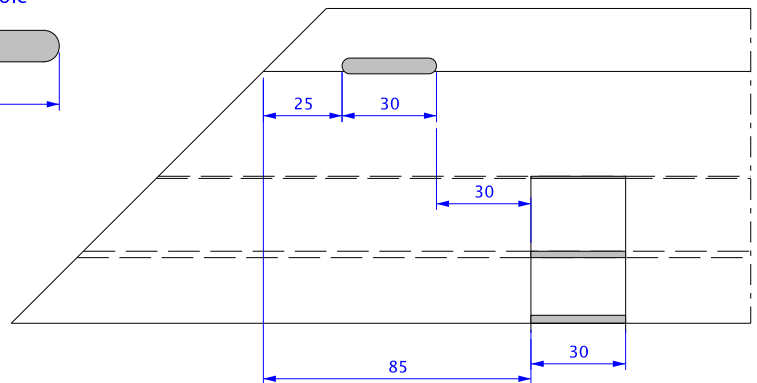
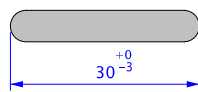

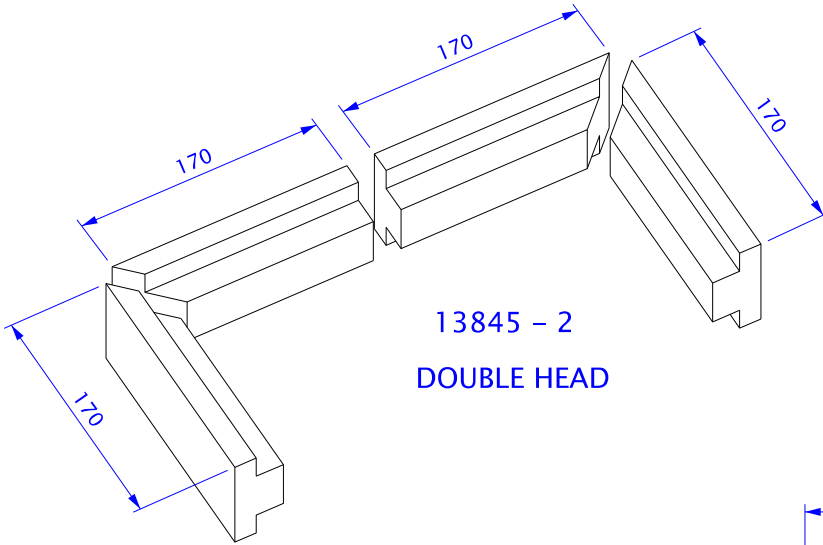

13845 - 2
DOUBLE HEAD

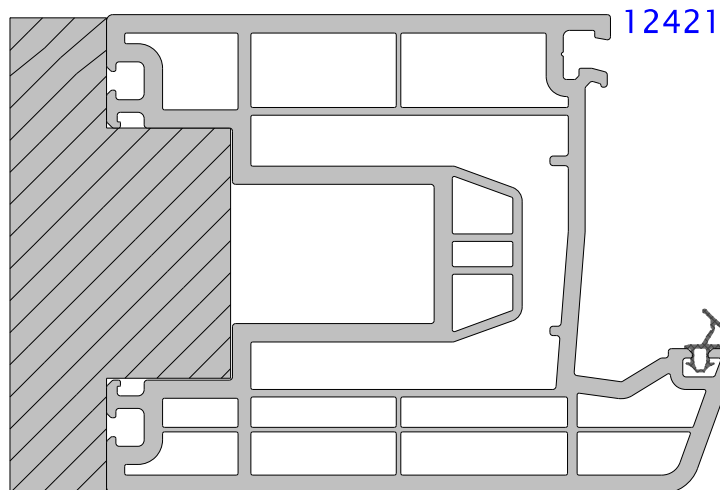
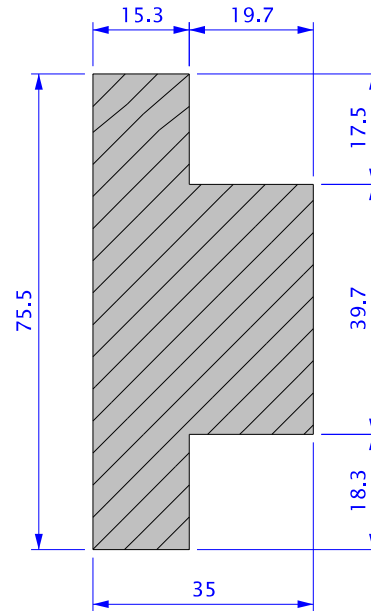

12421

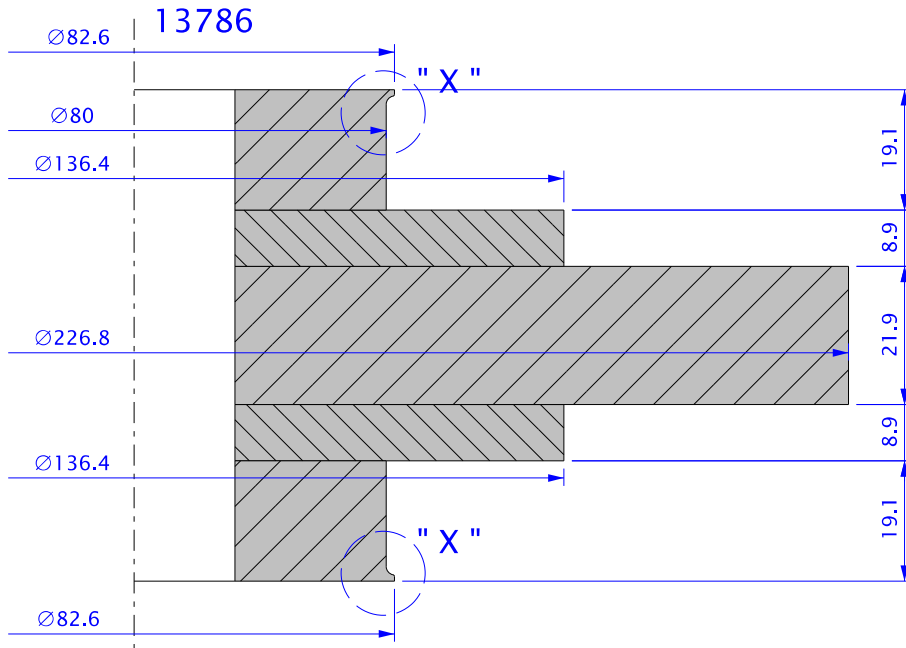

X DETAIL

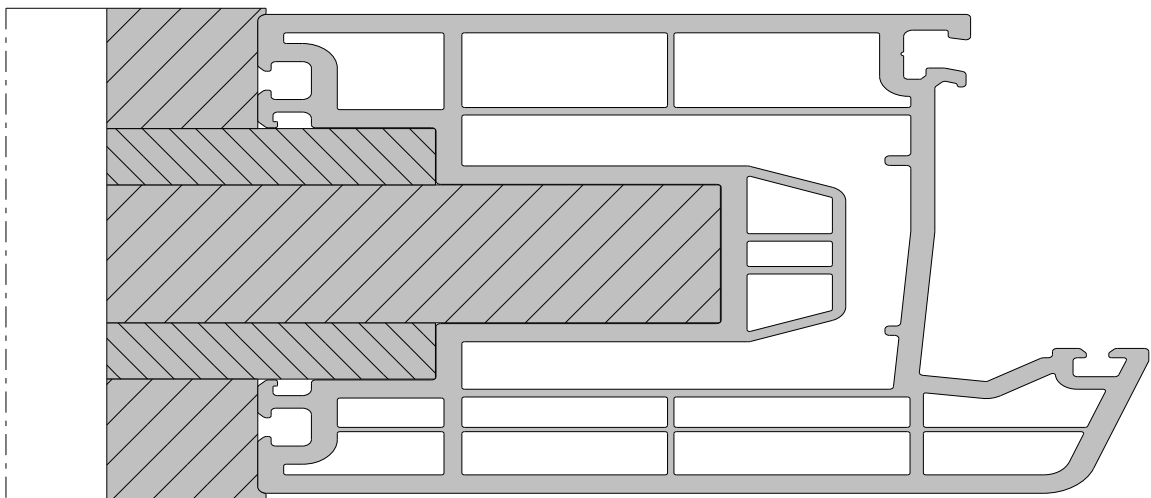
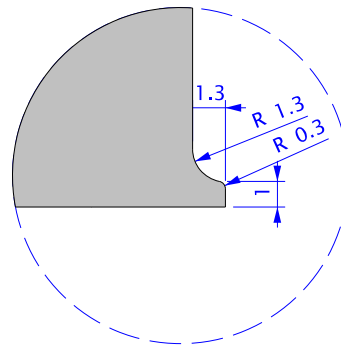

OPENING TYPE

A SCHEMA

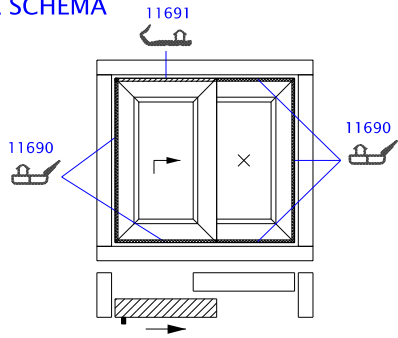

D SCHEMA

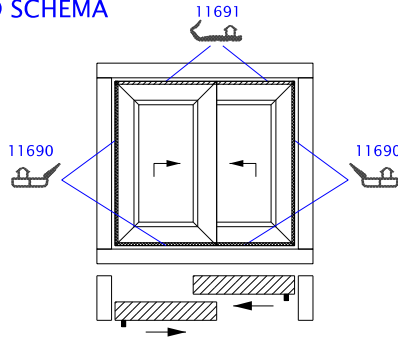

G3 SCHEMA

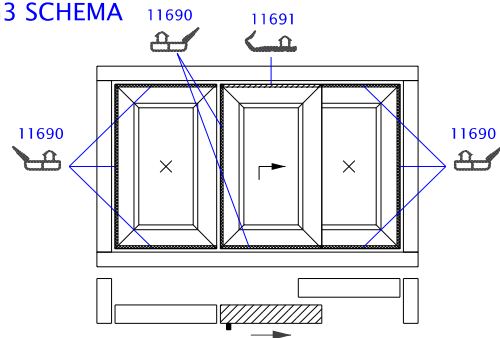

C SCHEMA

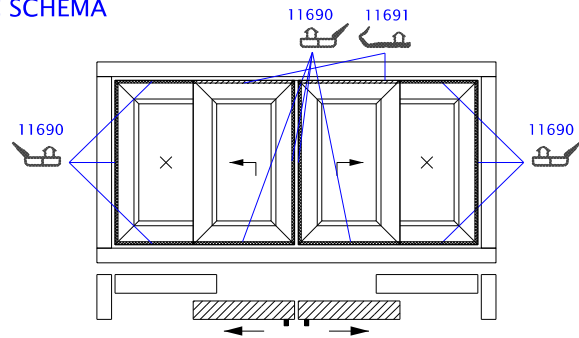

F SCHEMA

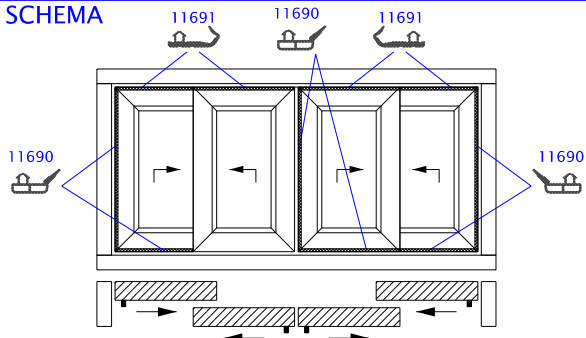

11690



11691

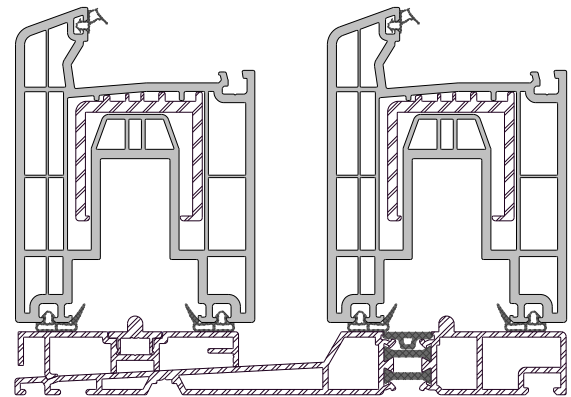
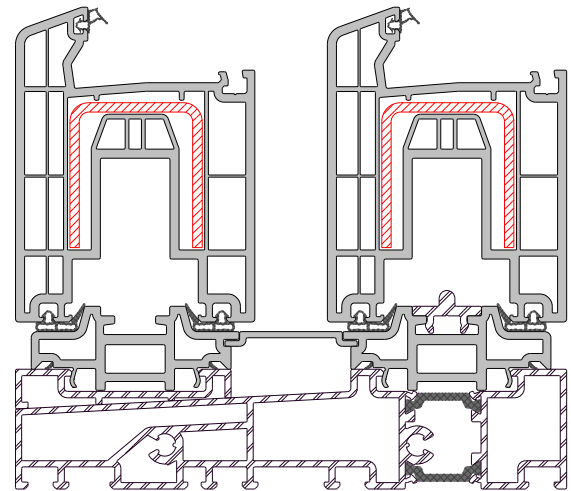
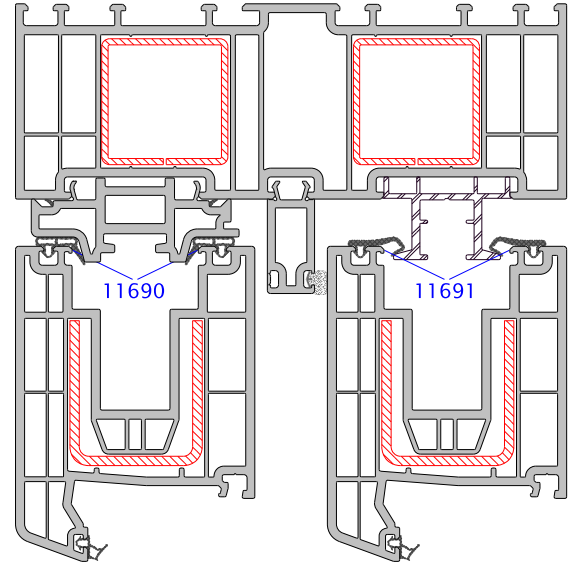

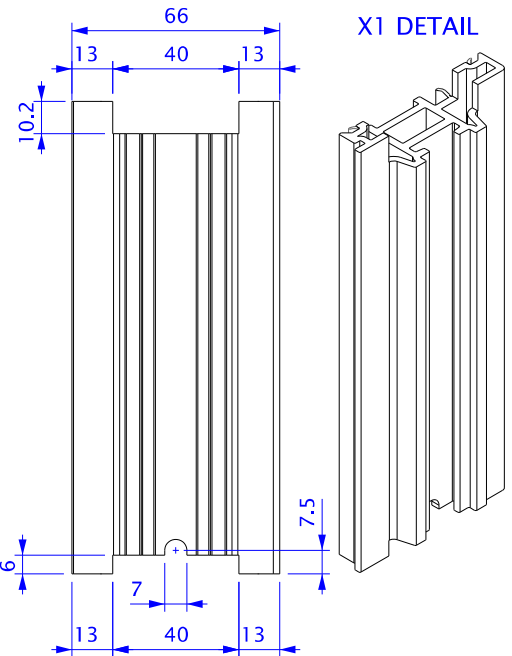
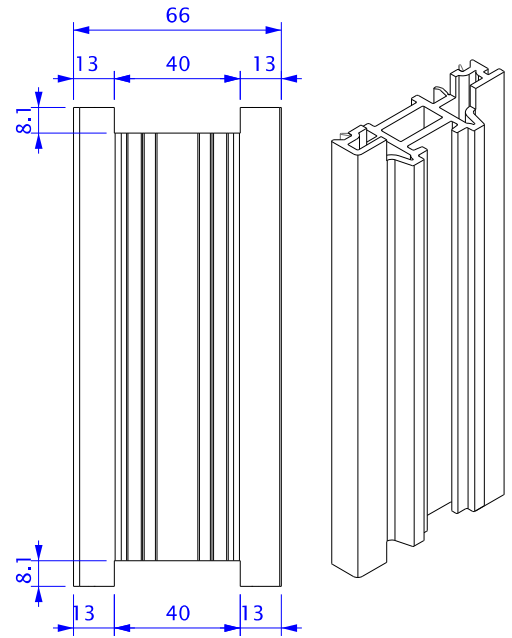
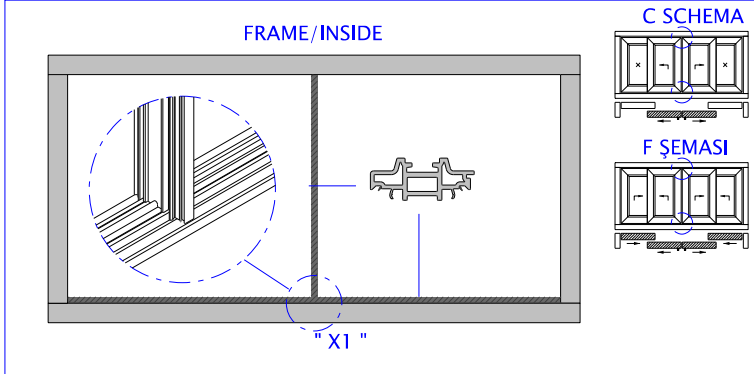
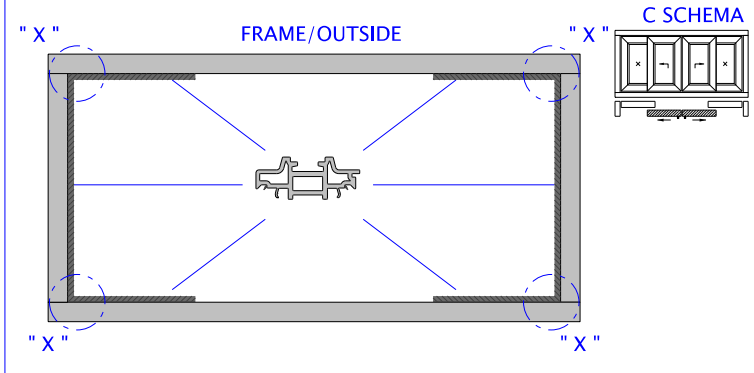
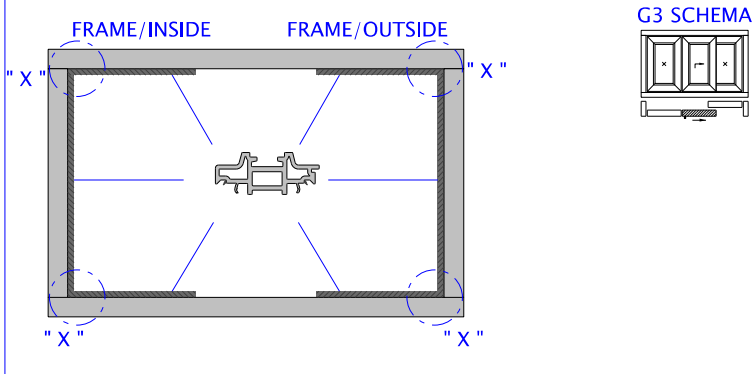
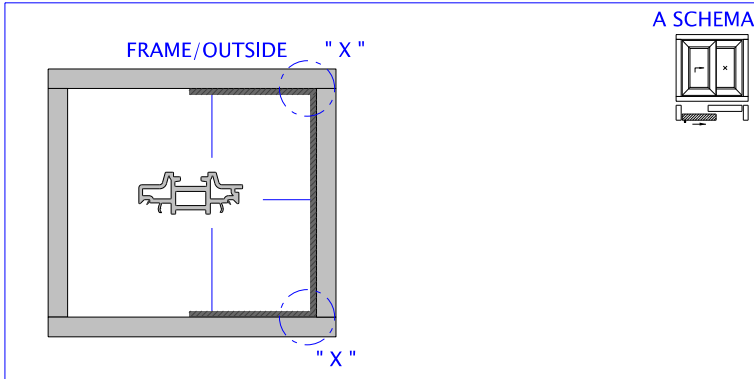
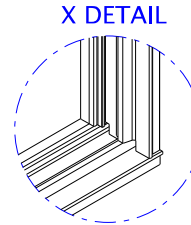
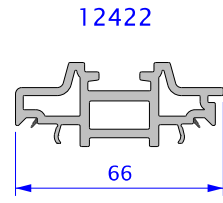
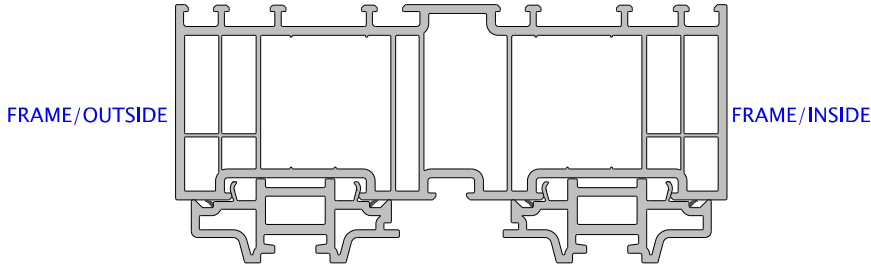

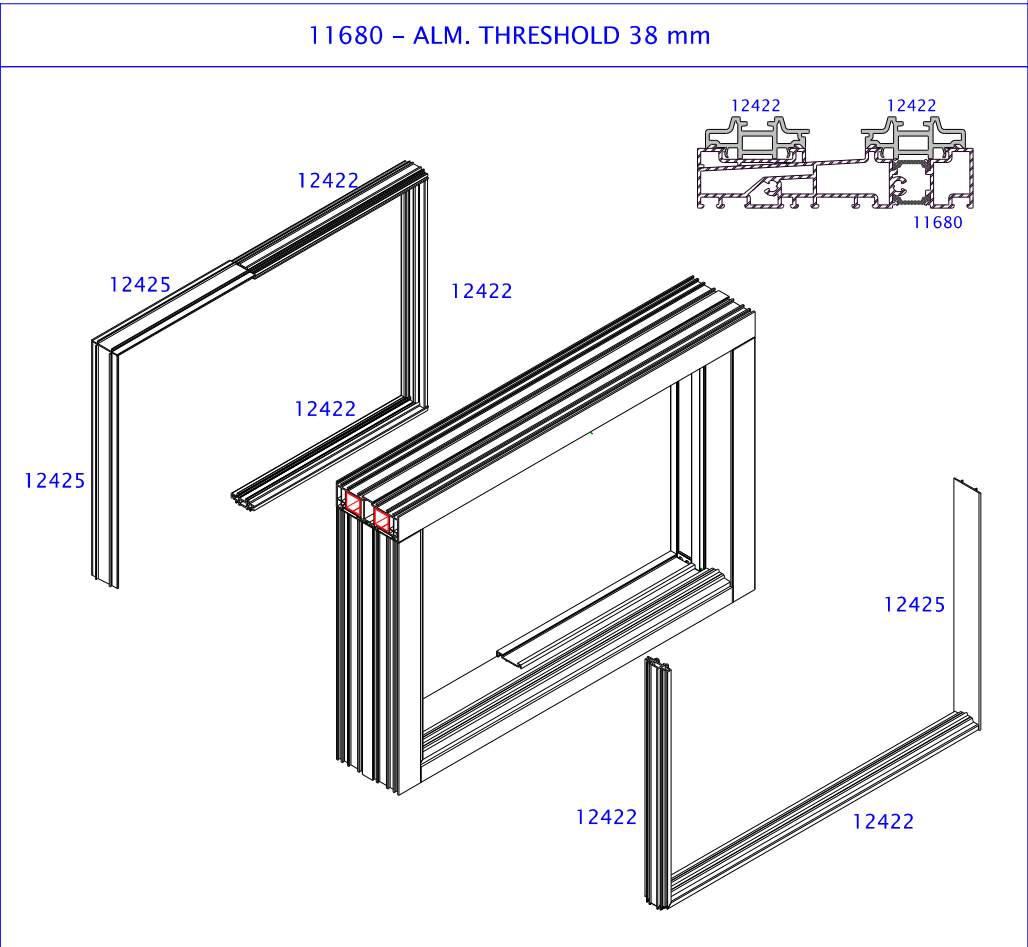
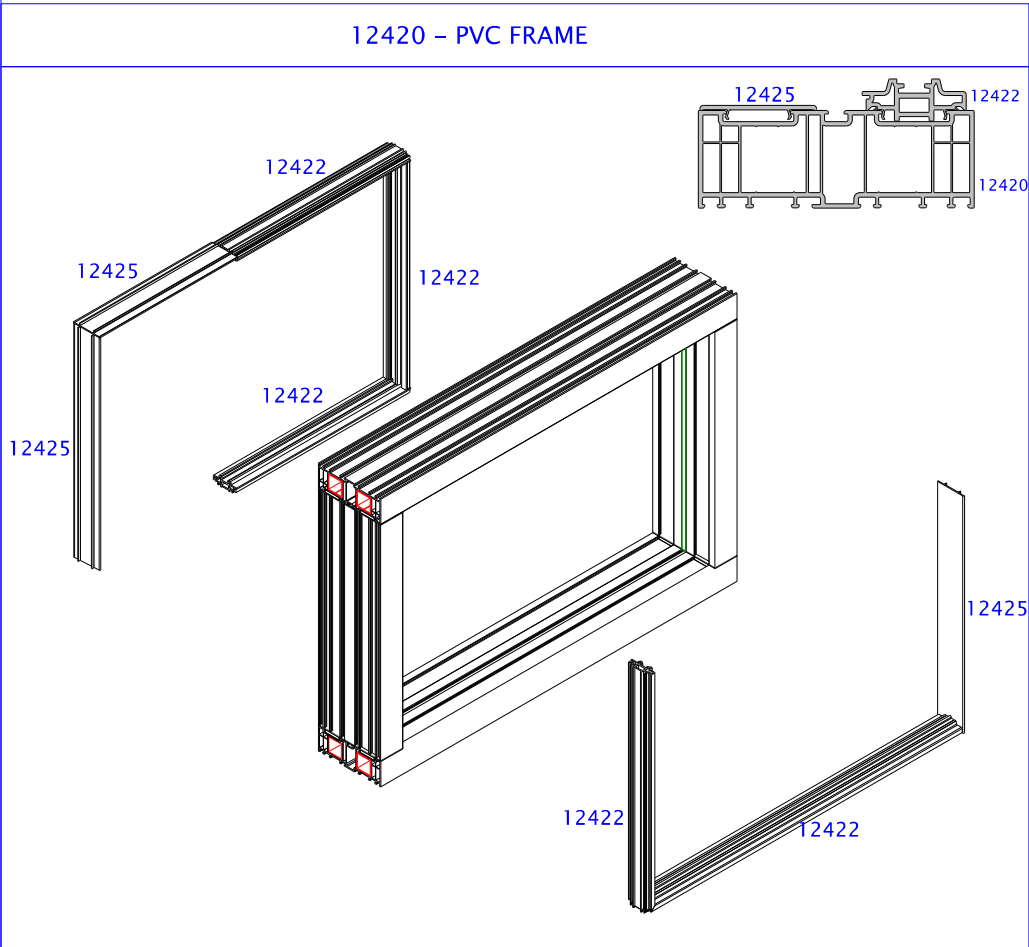
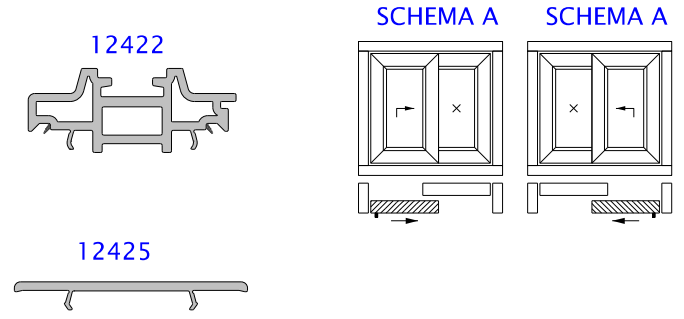
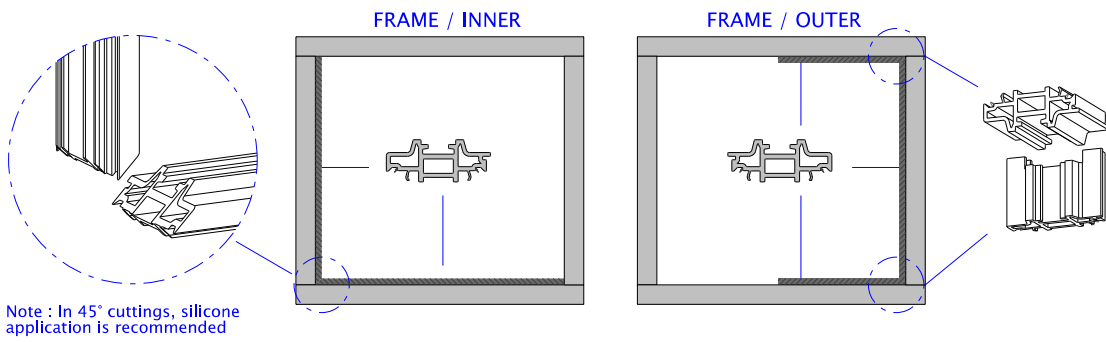

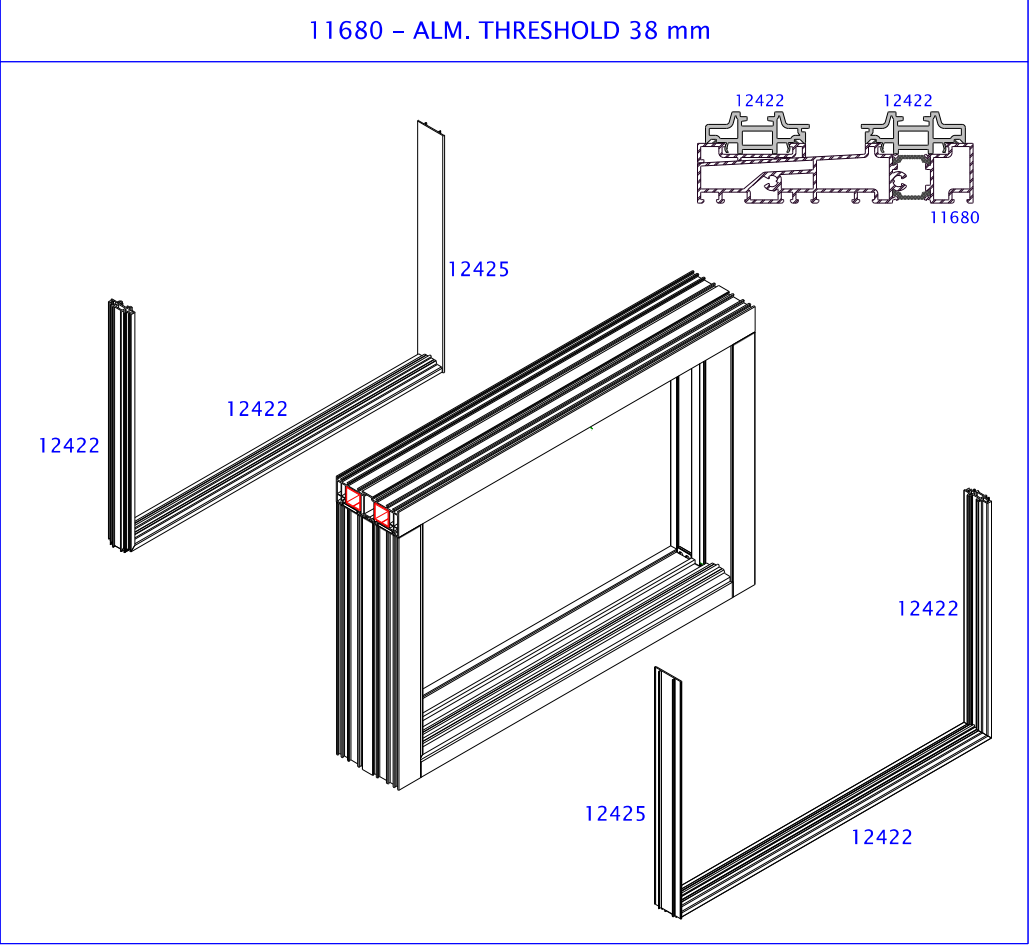
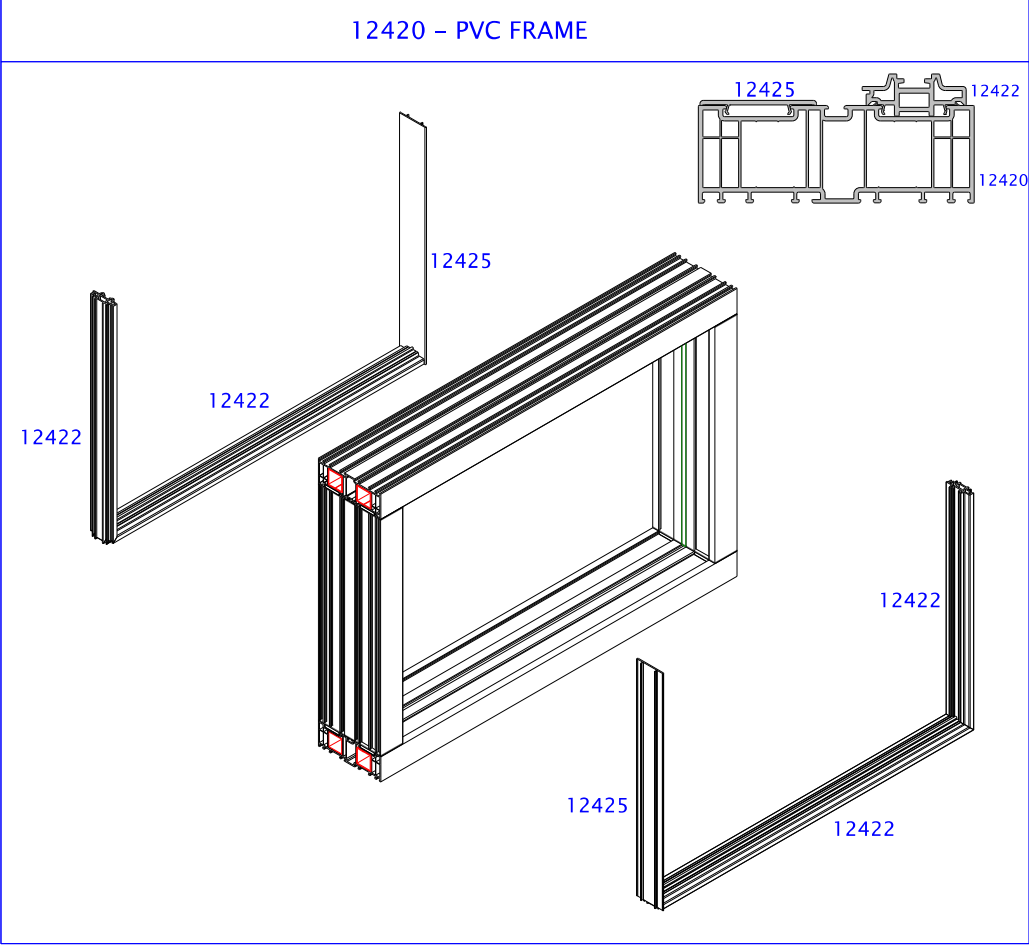
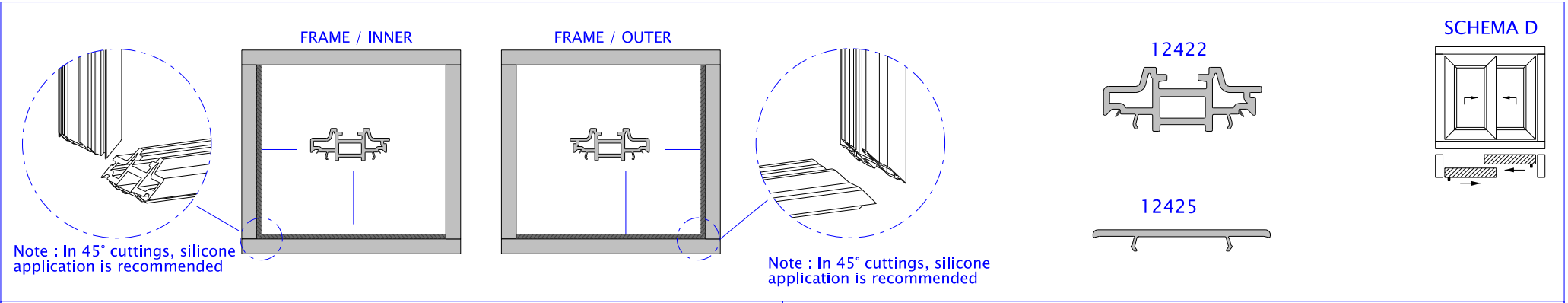

Deceuninck has the rights to change this tec.doc without any prior notice

FABRICATION

12422 - LOCKING CONNECTION DETAILS (SCHEMA C)
12425 - CLOSING PROFILE CONNECTION DETAILS

FRAME / INNER

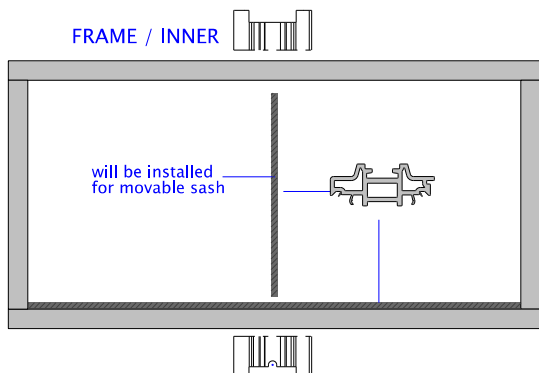

KASA / DIŞ

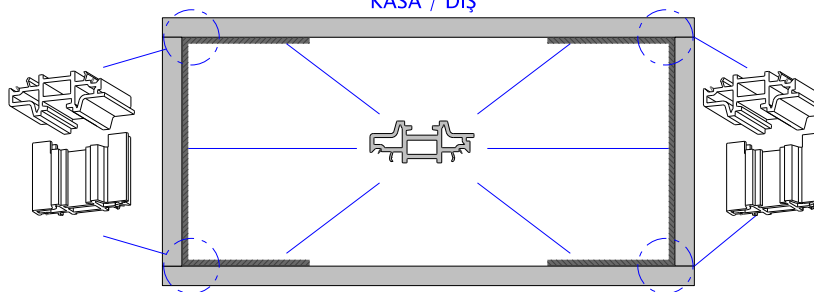

SCHEMA C

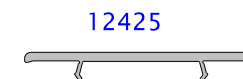
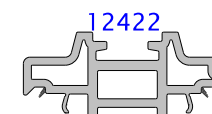
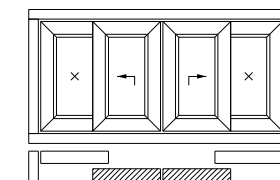

12420 - PVC FRAME

11680 - ALM. THRESHOLD 38 mm

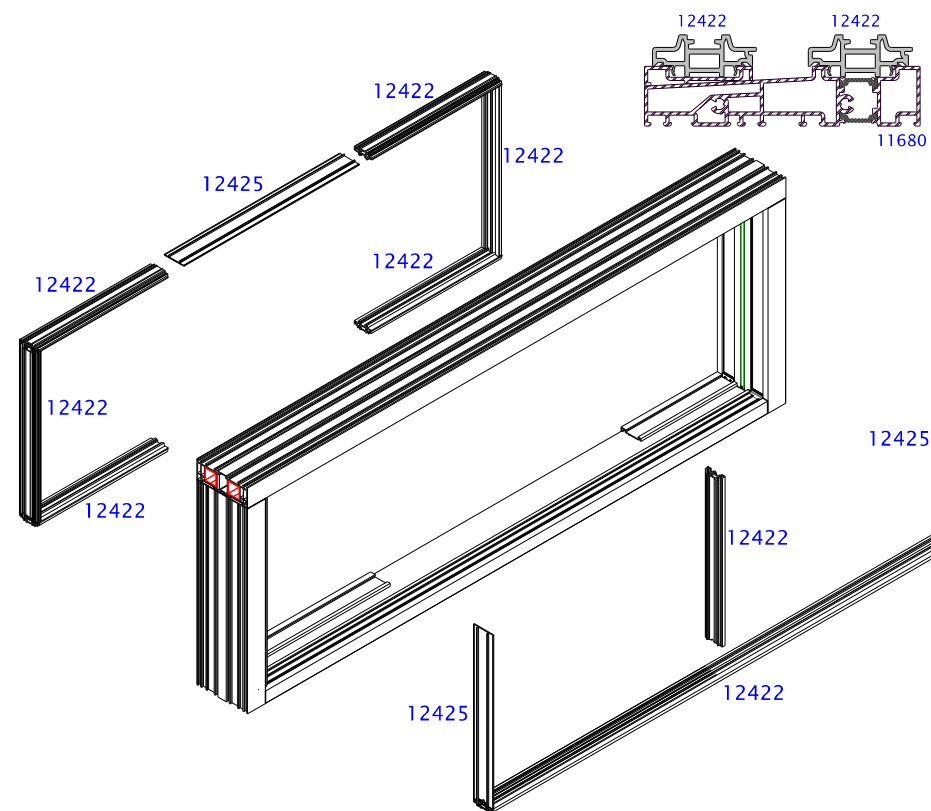
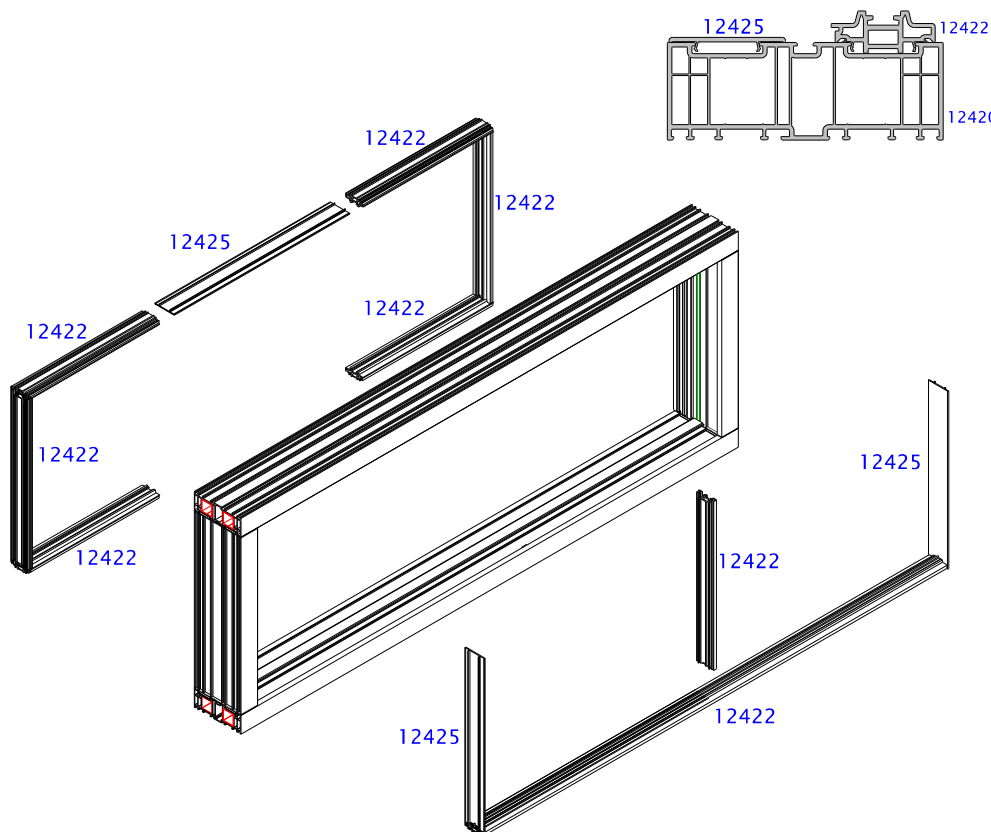

FABRICATION

12422 – LOCKING CONNECTION DETAILS (SCHEMA F)
12425 – CLOSING PROFILE CONNECTION DETAILS

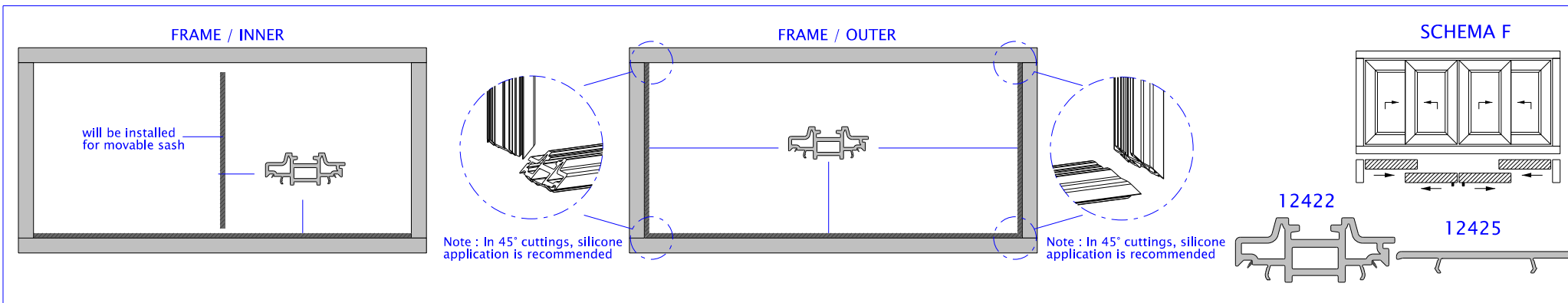

12420 – PVC FRAME

11680 – ALM. THRESHOLD 38 mm

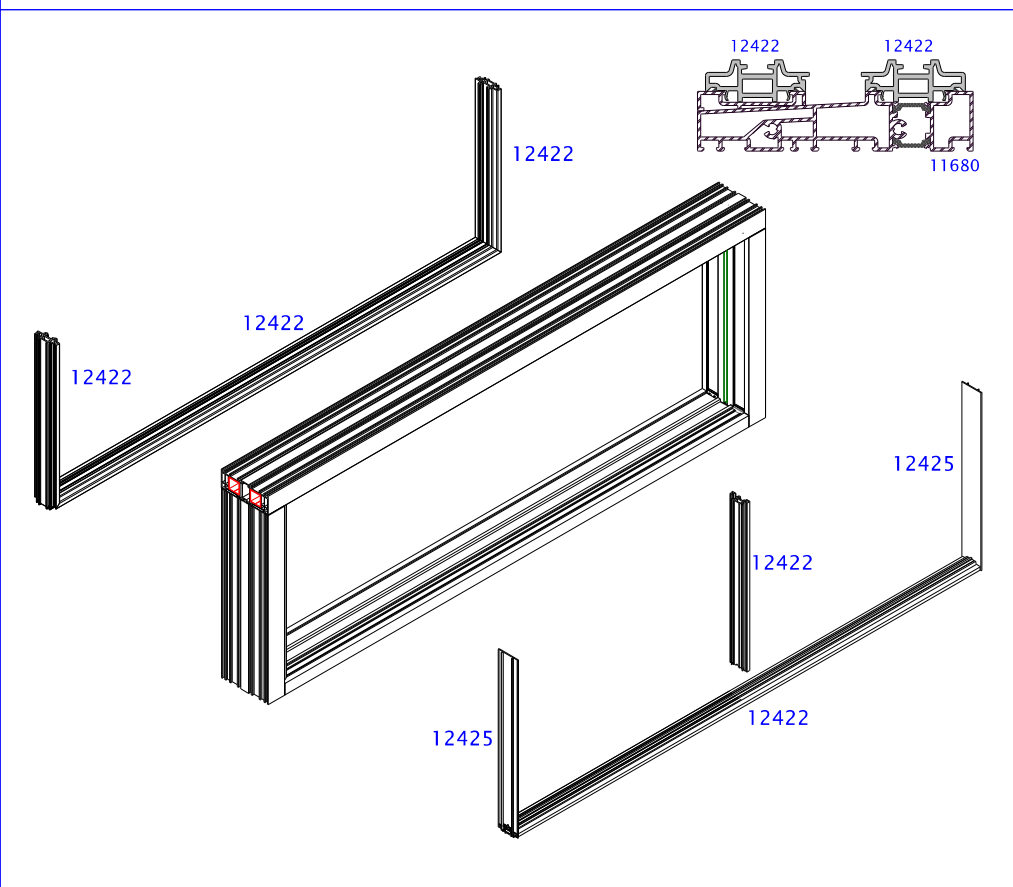
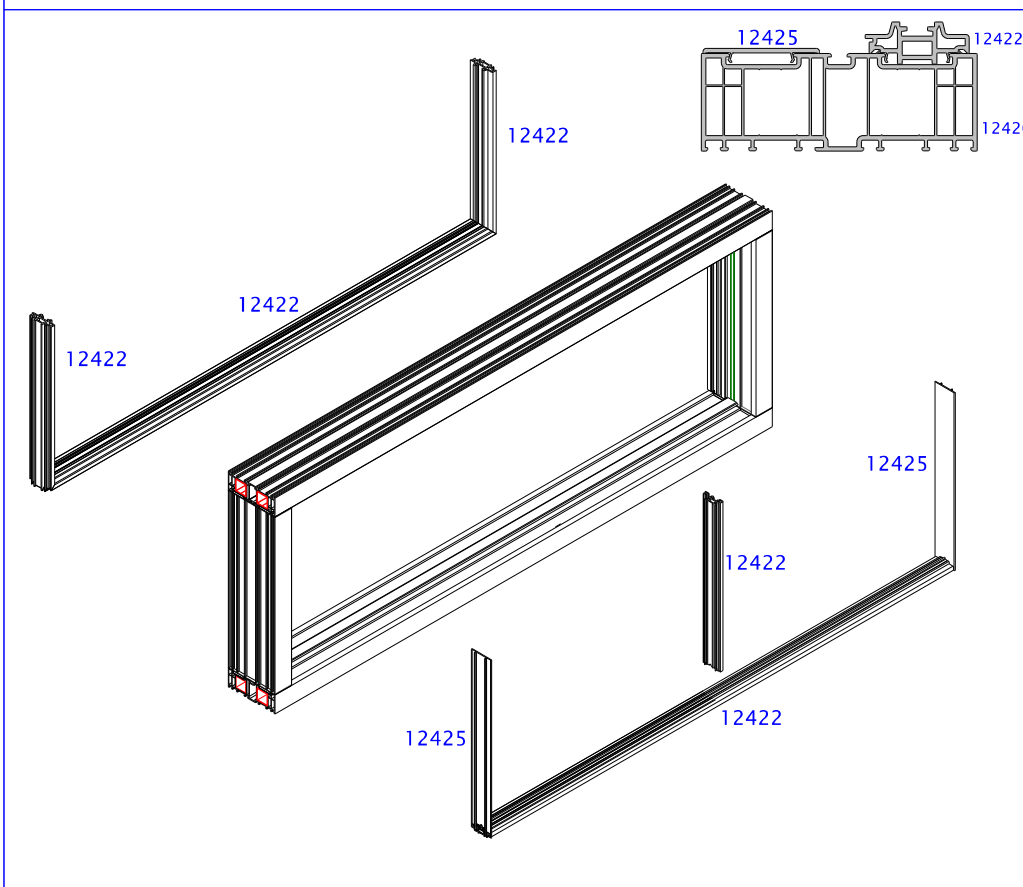

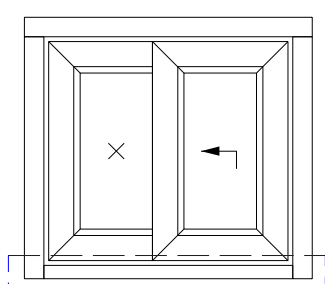

SECTION A

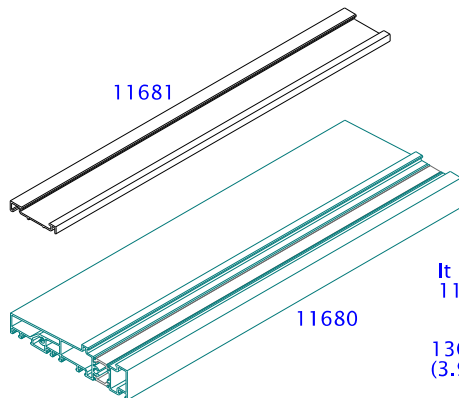
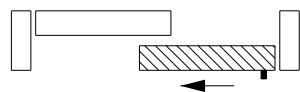

11681

11680

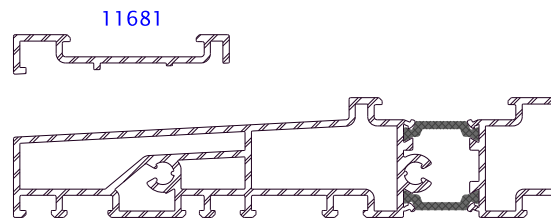

11681

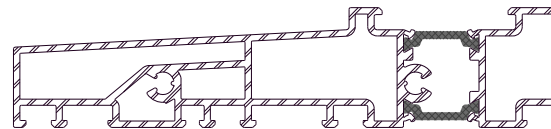

11680

It is recommended before screwing,
11681 must be countersunk

13000
(3.9°*16)

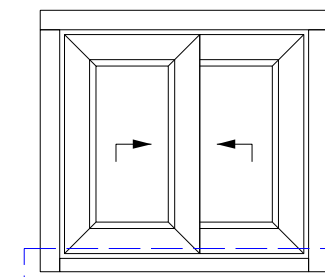
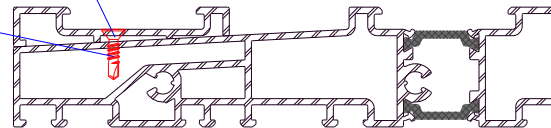

SECTION B

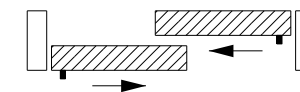

SINGLE OPENING

DOUBLE OPENING

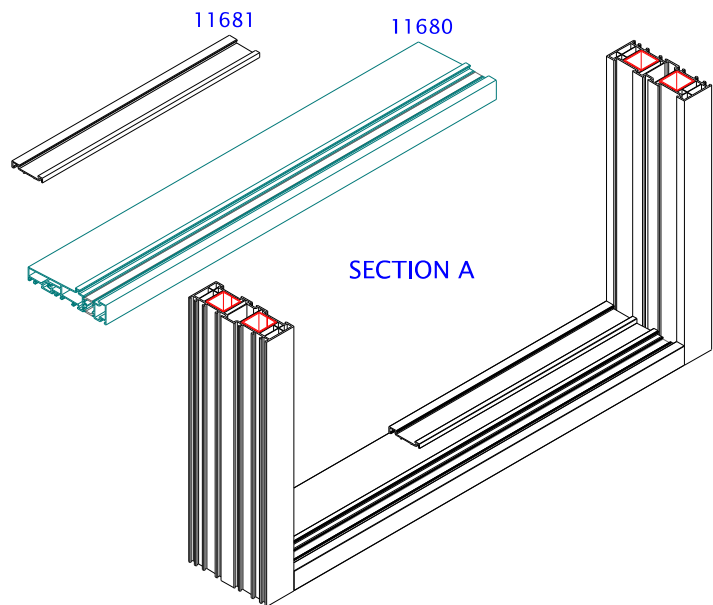

11681

11680

SECTION A

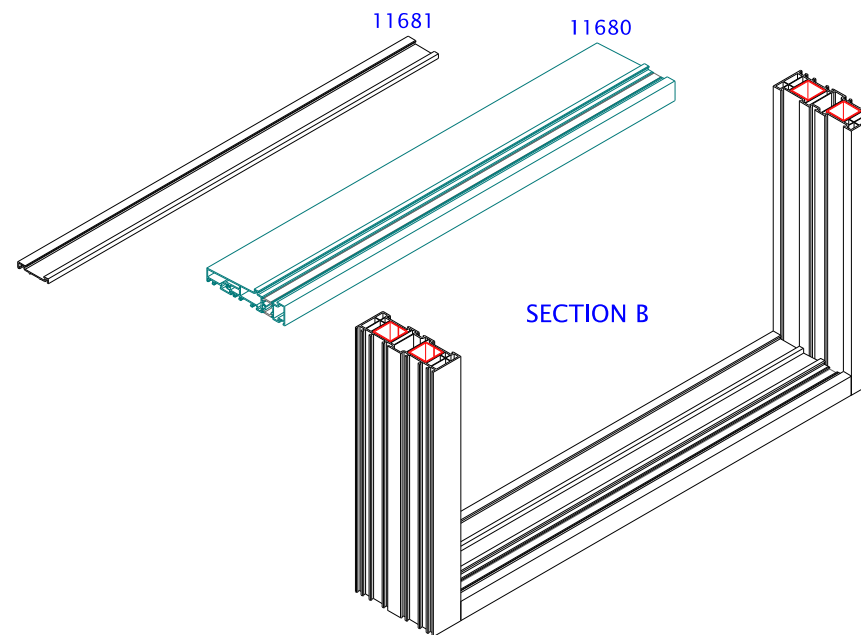

11681

11680

SECTION B

APPLICATIONS of BOTTOM SUPPORT WEDGE with CHANNEL

11696 - BOTTOM SUPPORT WEDGE with CHANNEL 9 mm

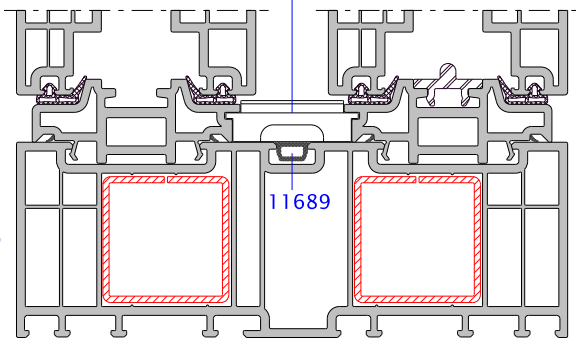
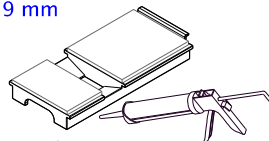

12420

11689

11689

For prevent the water leakage, 11689 is installed the gap which was inserted middle closing, in PVC bottom frame applications.

11697 - BOTTOM SUPPORT WEDGE with CHANNEL 16 mm

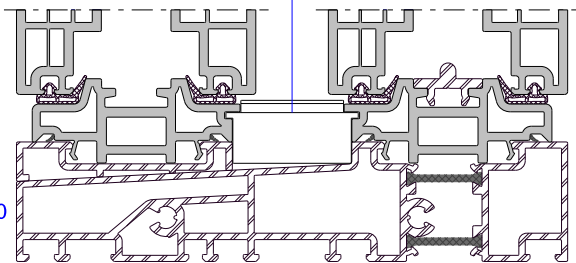
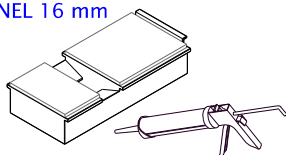

11680

FIXED SASH SUPPORT APPLICATIONS

11695-FIXED SASH SUPPORT

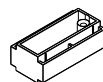

13016 (4.2x38)

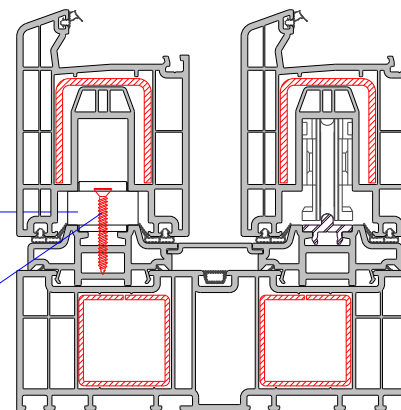

13026 (7.5x120) installation screw

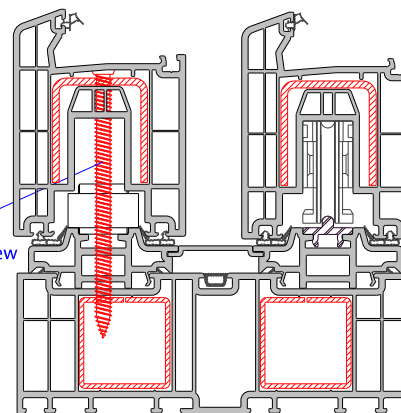

11695
11696 - 11697

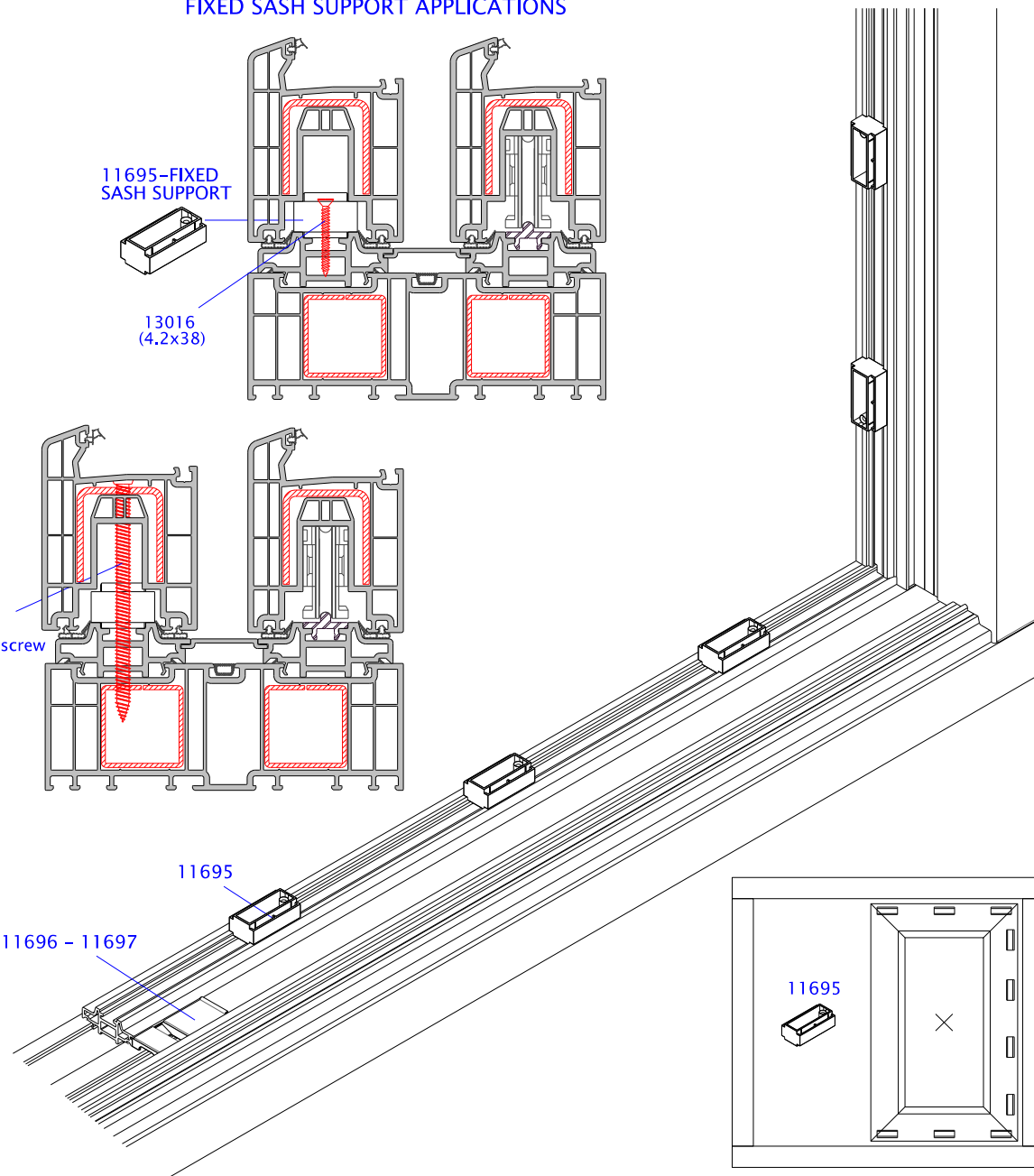

11695

FABRICATION

12422 – LOCKING CONNECTION DETAILS (SCHEMA A)
12425 – CLOSING PROFILE CONNECTION DETAILS

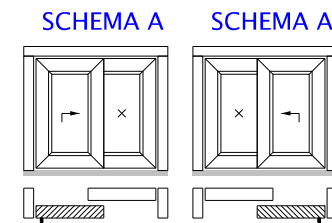
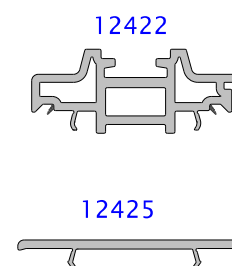
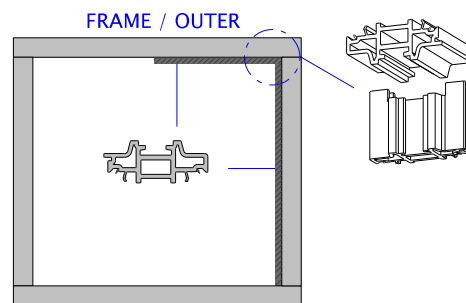
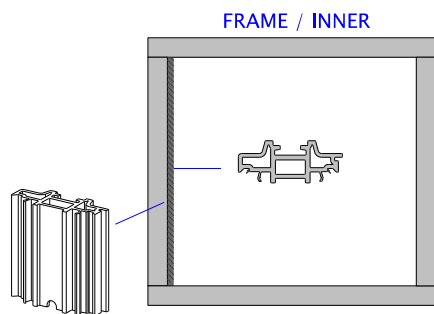

11678 – HS76 ALM. THRESHOLD 20 MM

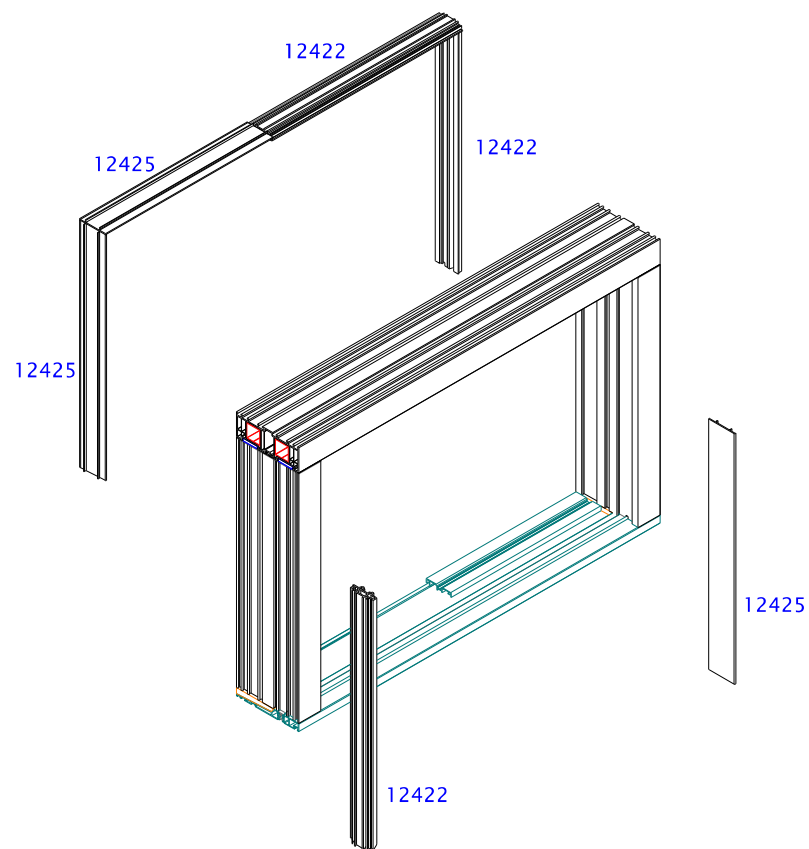

FABRICATION

12422 - LOCKING CONNECTION DETAILS (SCHEMA D)
12425 - CLOSING PROFILE CONNECTION DETAILS

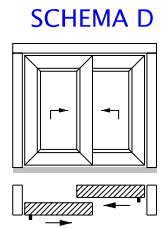
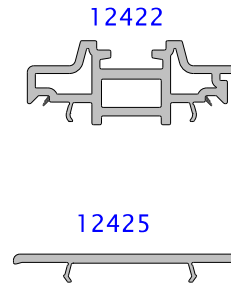
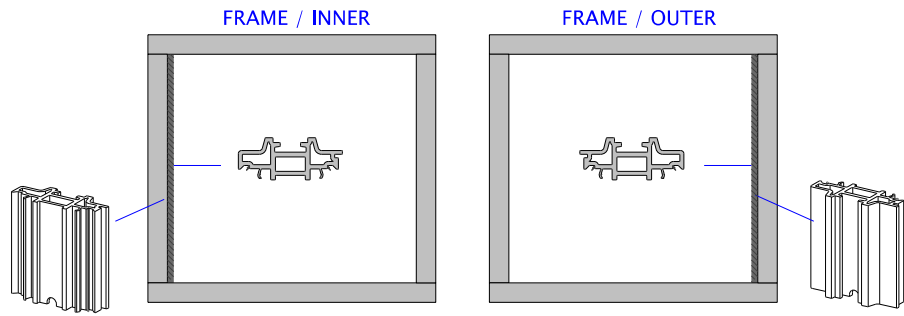

11678 - HS76 ALM. THRESHOLD 20 MM

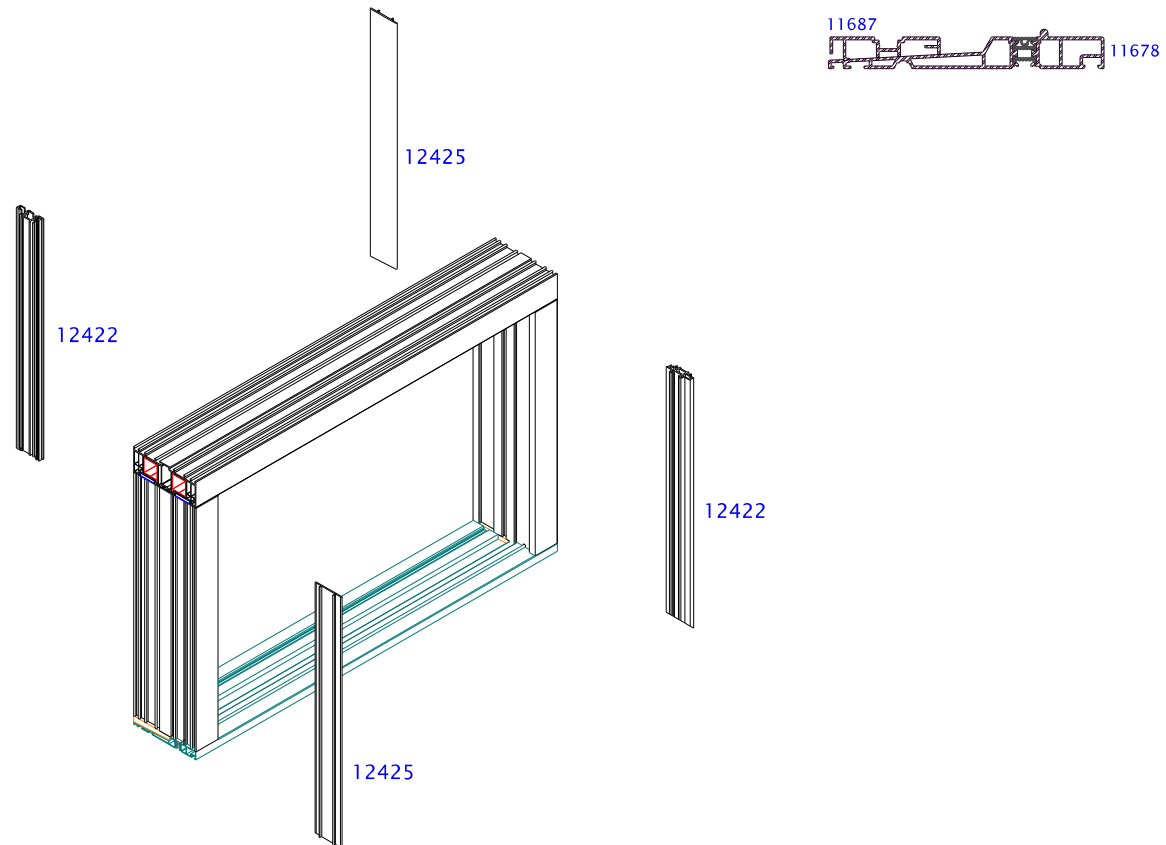

FABRICATION

12422 - LOCKING CONNECTION DETAILS (SCHEMA C)
12425 - CLOSING PROFILE CONNECTION DETAILS

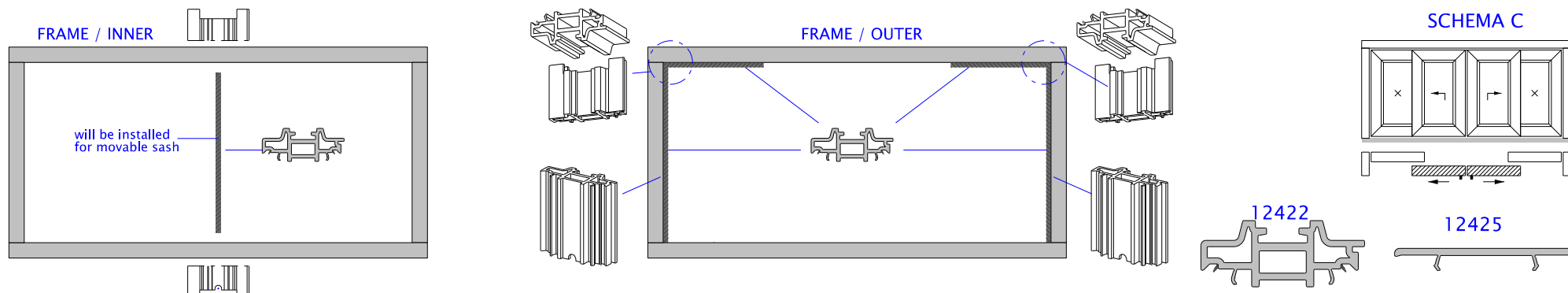

11678 - HS76 ALM. THRESHOLD 20 MM

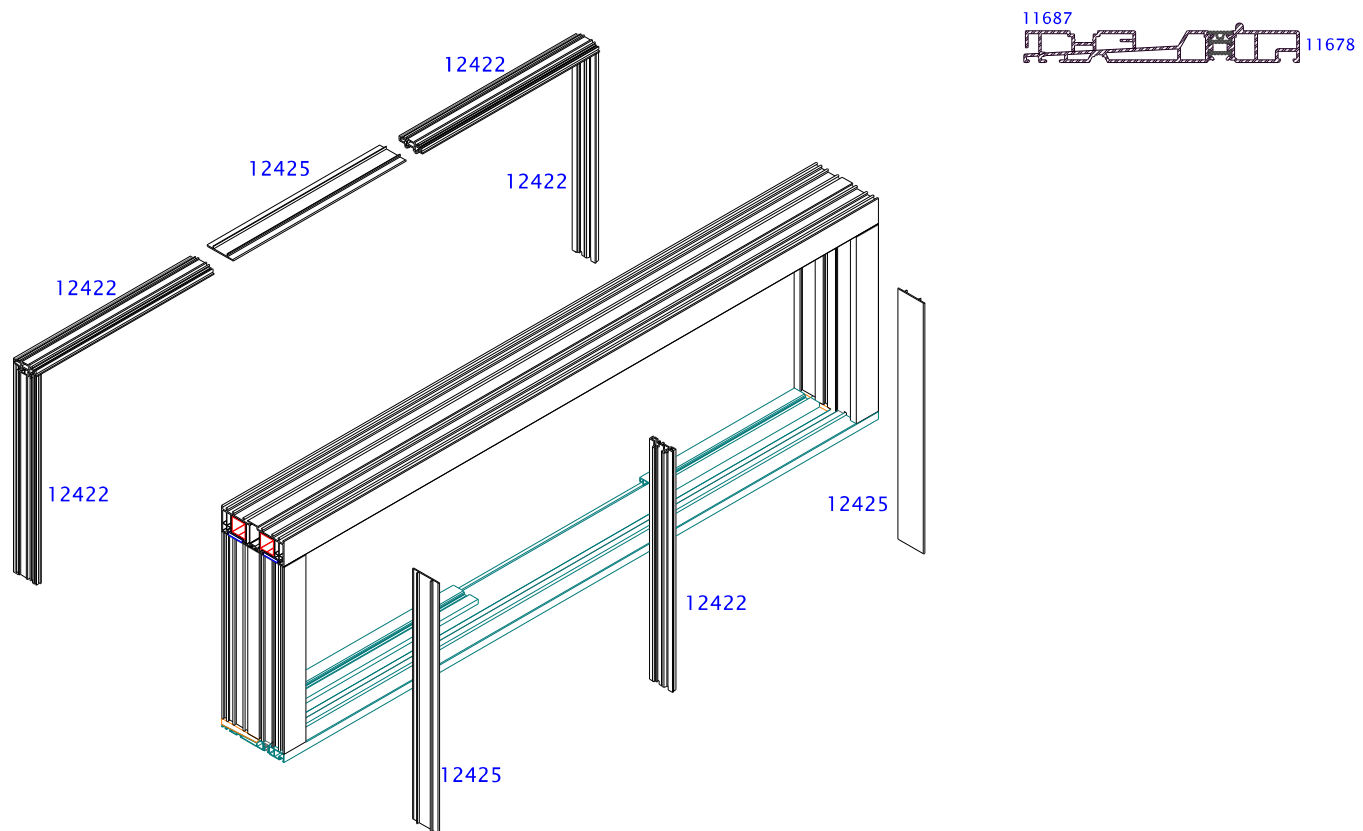

FABRICATION

12422 - LOCKING CONNECTION DETAILS (SCHEMA F)
12425 - CLOSING PROFILE CONNECTION DETAILS

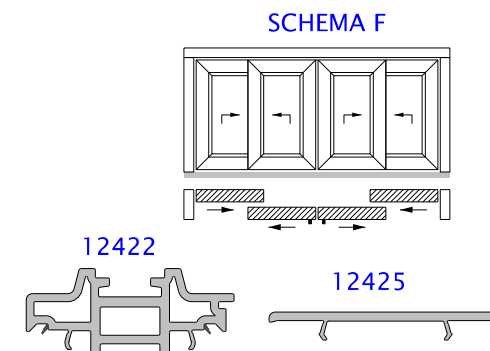
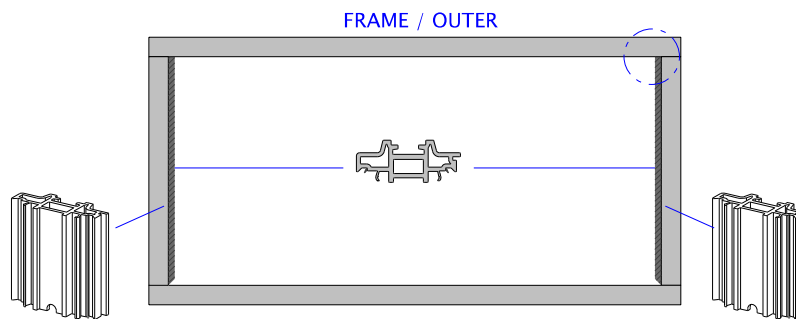
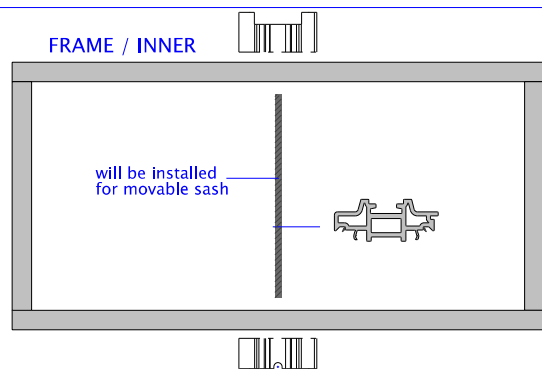

11678 - HS76 ALM. THRESHOLD 20 MM

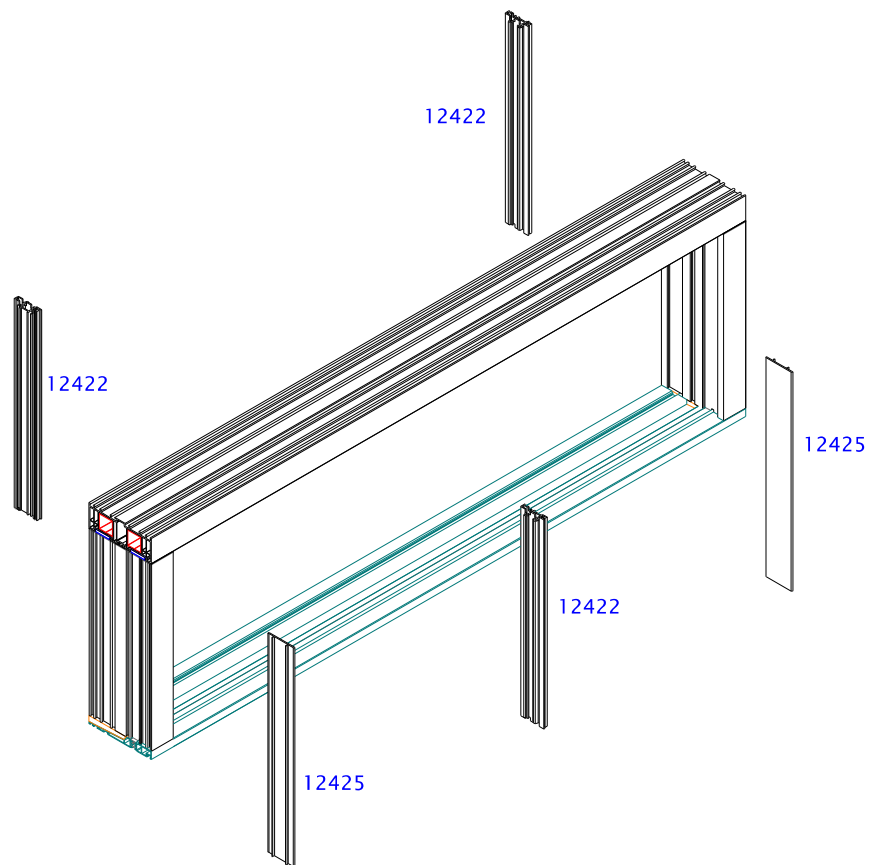

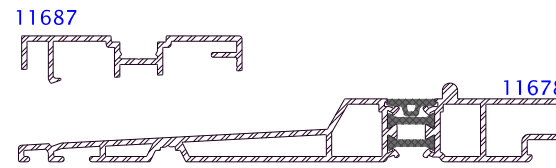
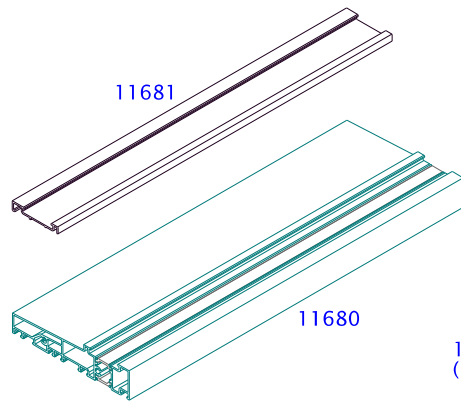
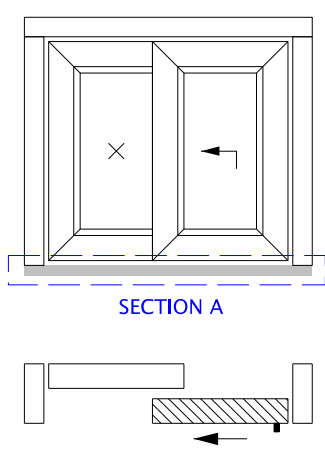

It is recommended before screwing,
 11681 must be countersunk

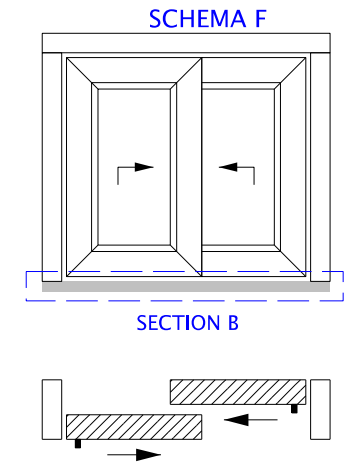
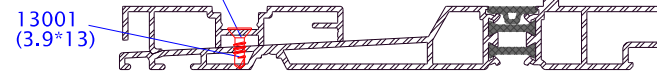

SINGLE OPENING

DOUBLE OPENING

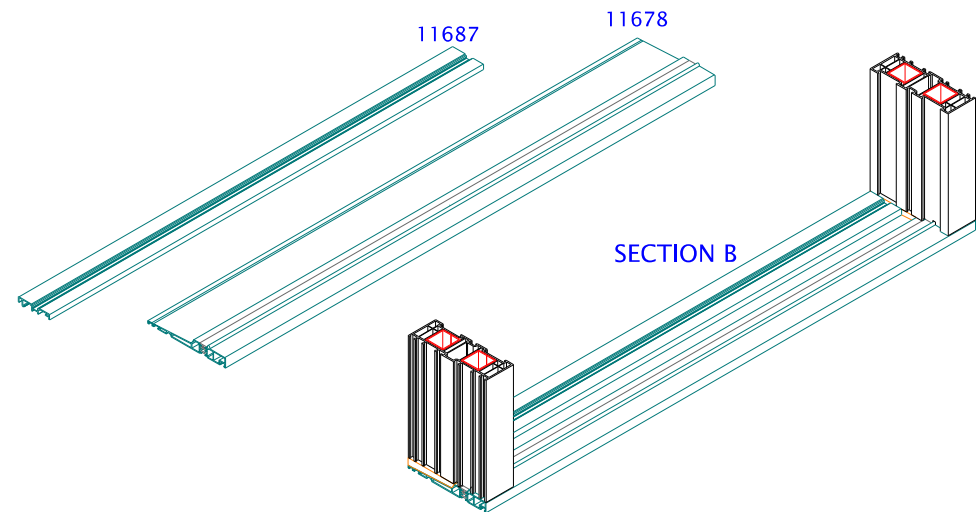
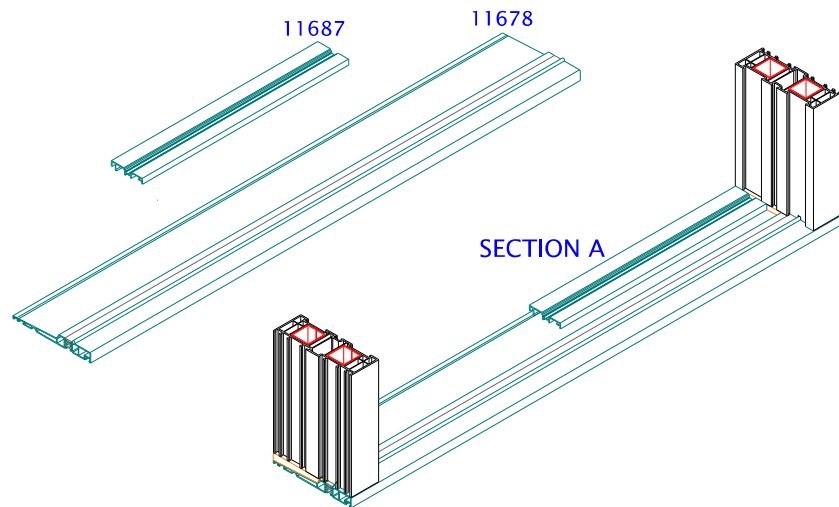

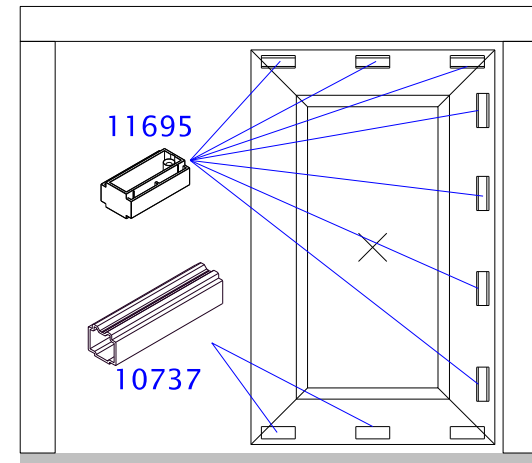
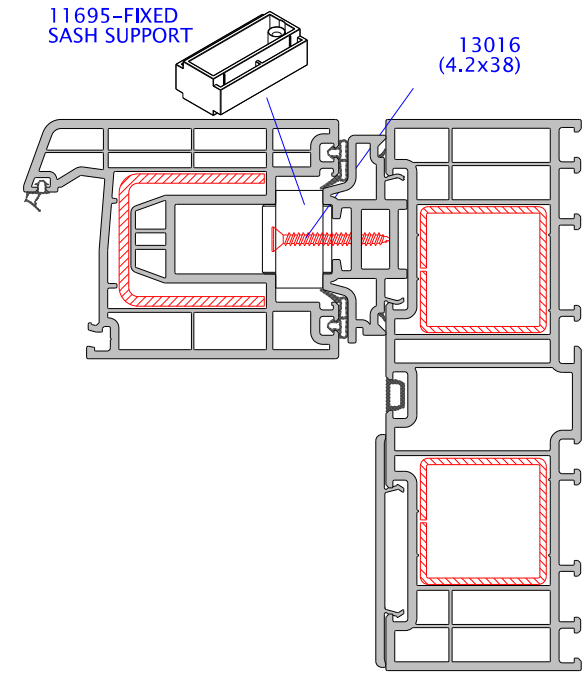
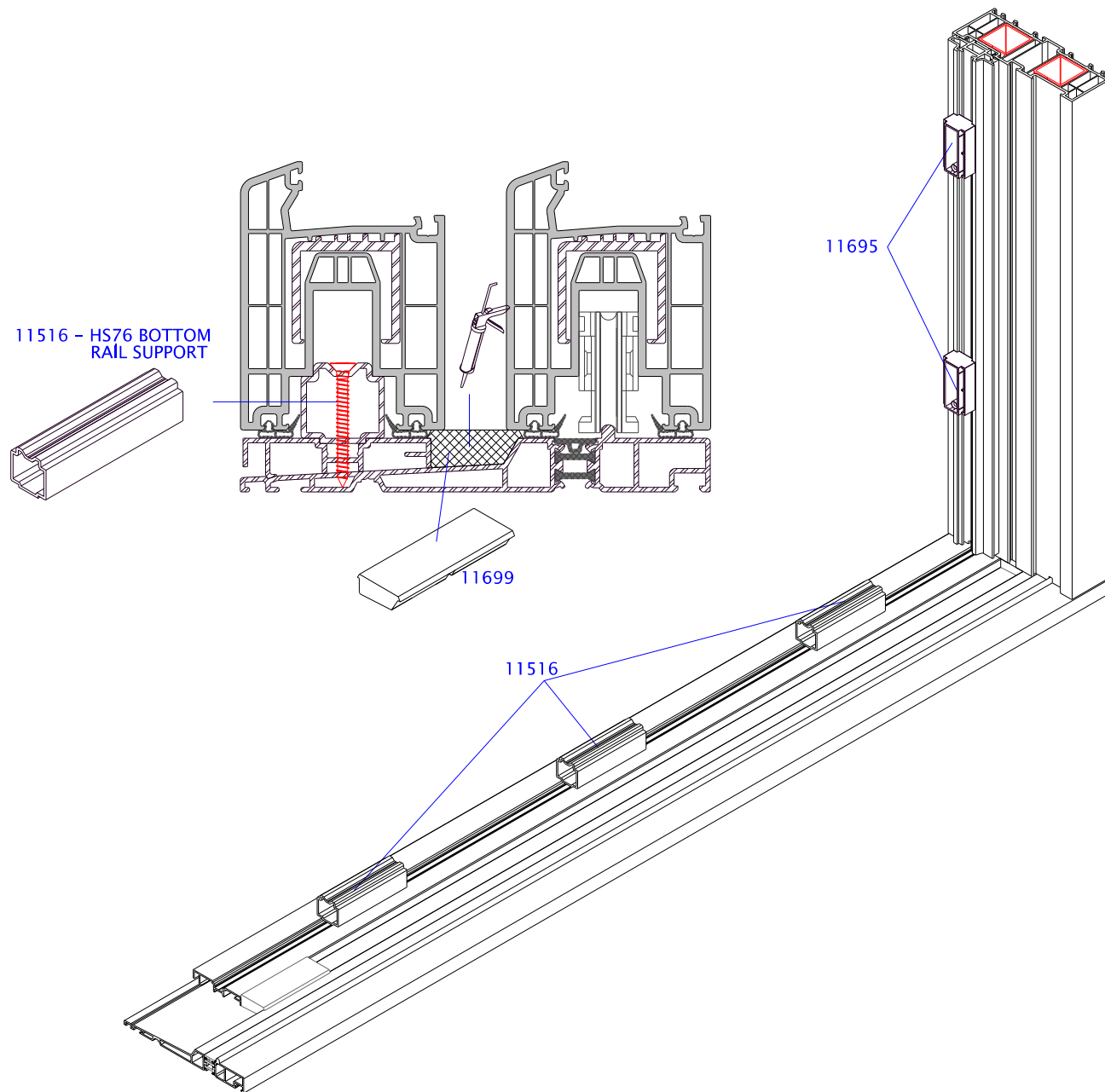

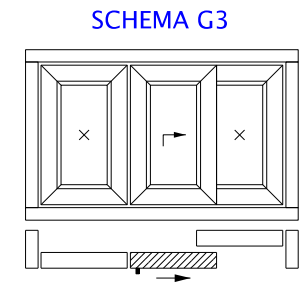
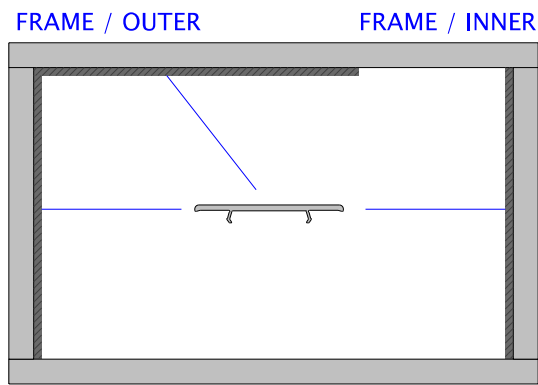
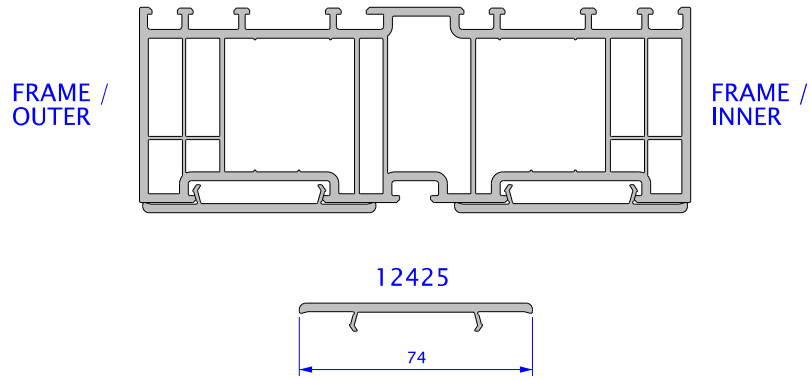

FRAME / OUTER

FRAME / INNER

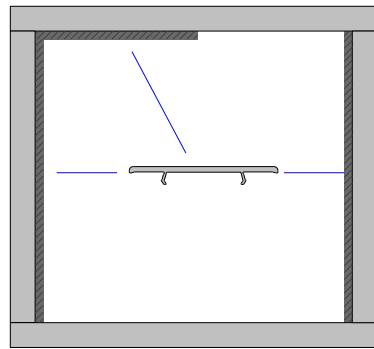

SCHEMA A

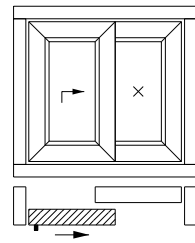

FRAME / OUTER

FRAME / OUTER

FRAME / INNER

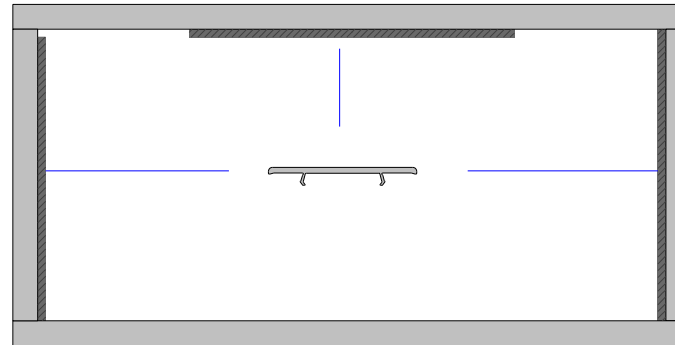

SCHEMA C

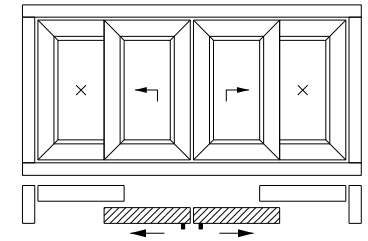

FRAME / OUTER

FRAME / INNER

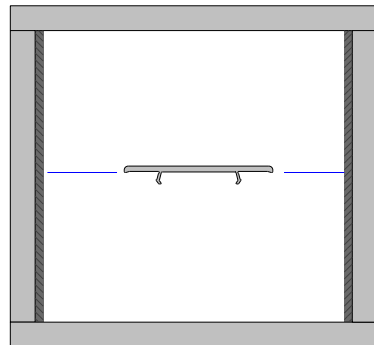

SCHEMA D

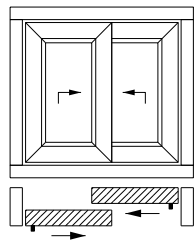

FRAME / INNER

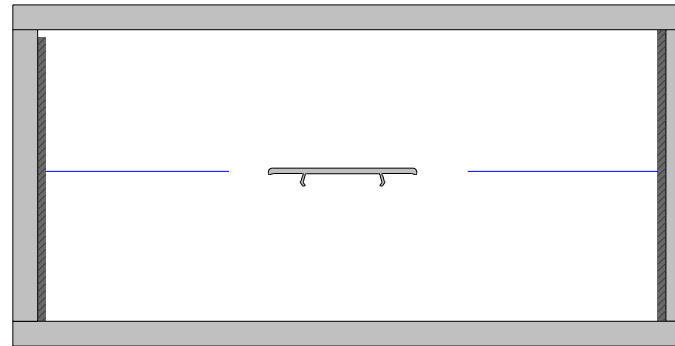

SCHEMA F

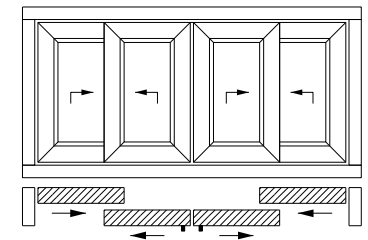

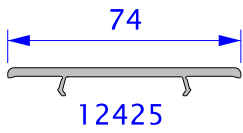

Milling Details of 12425

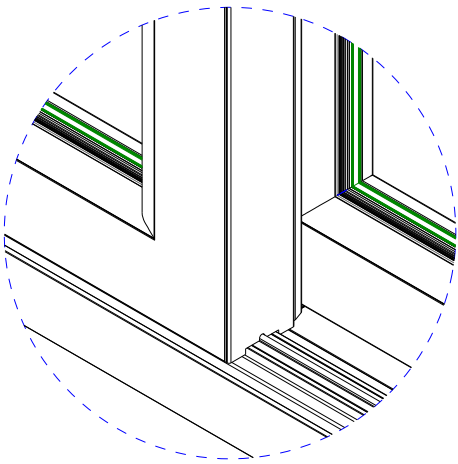
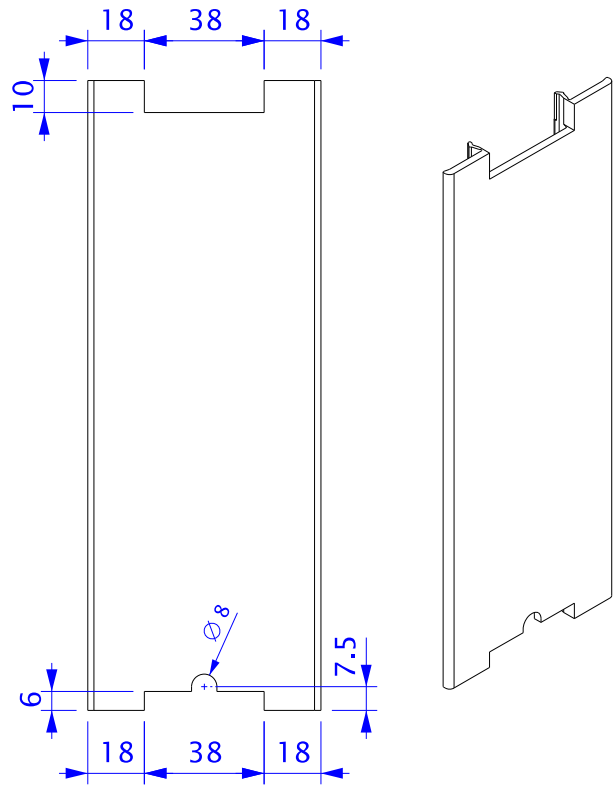
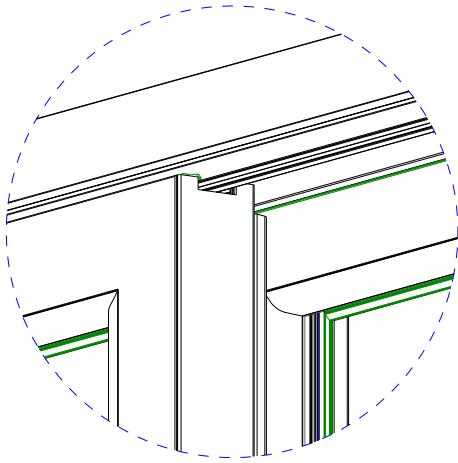

12425 - Fixed Sash Cutting Details

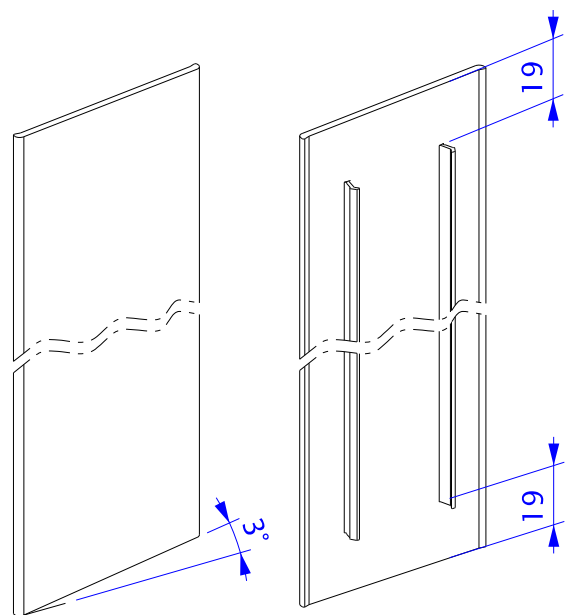
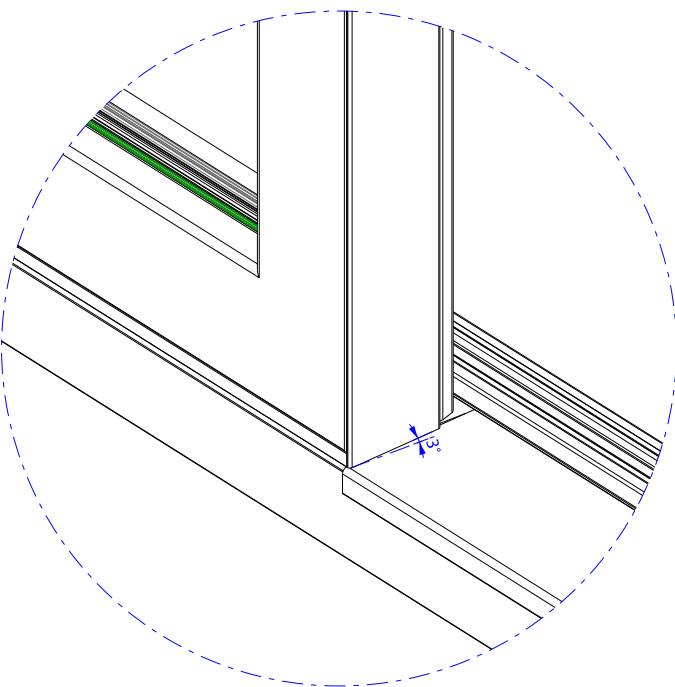

OUTER FRAME

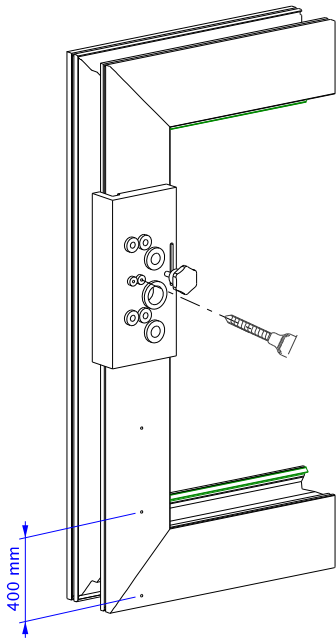

INNER FRAME

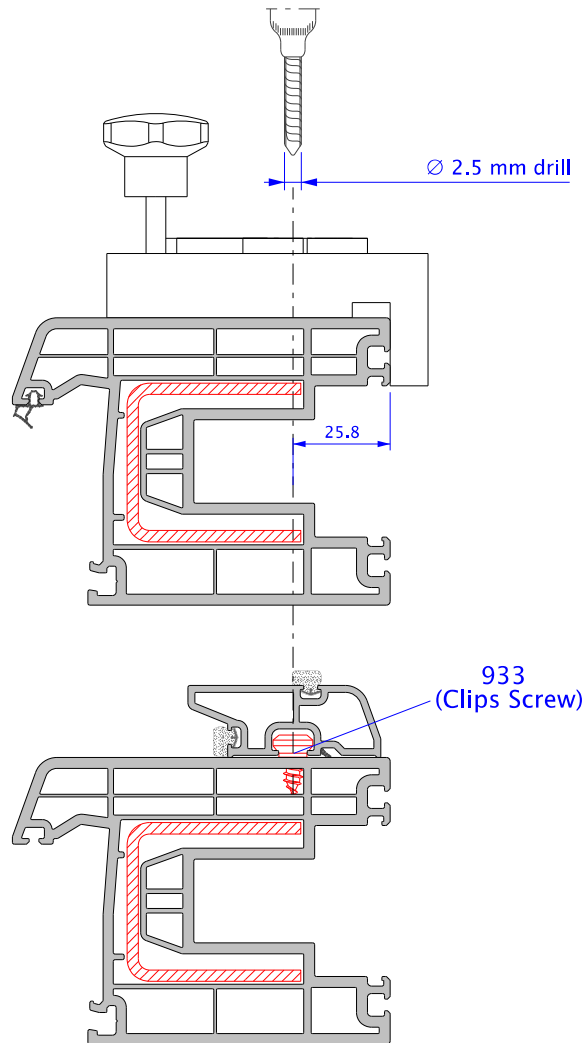
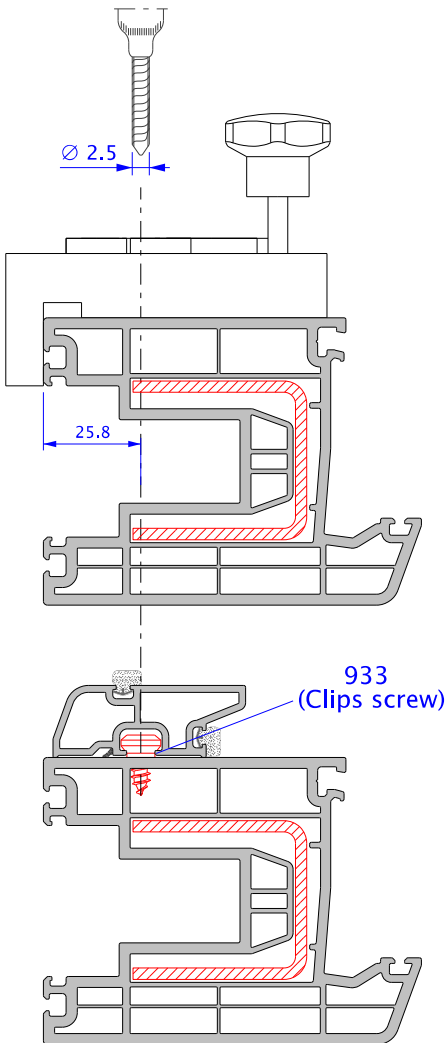
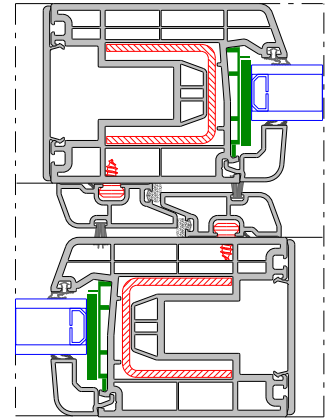
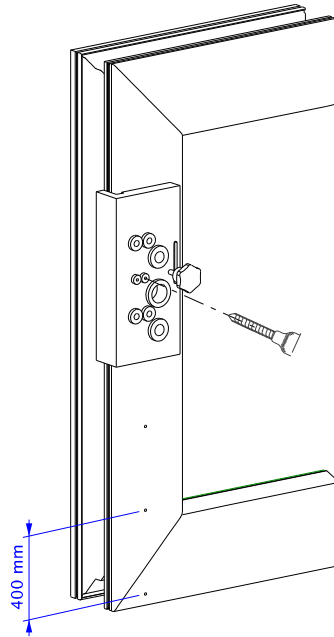

FRAME / OUTER

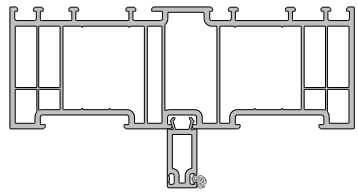

FRAME / INNER

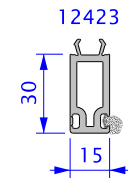

12423

FRAME / OUTER

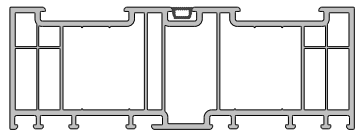

FRAME / INNER

11689

* 11689 is applied in the all mid channel, if the bottom frame consists of PVC.

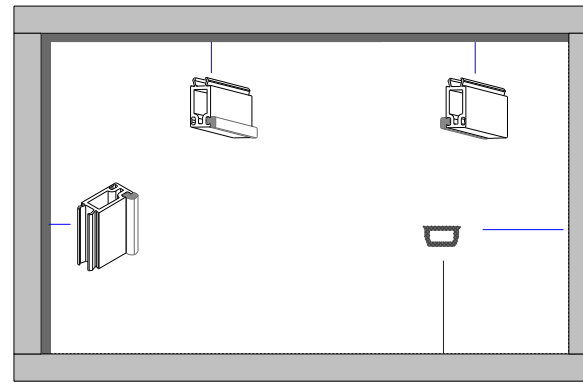

SCHEMA G3

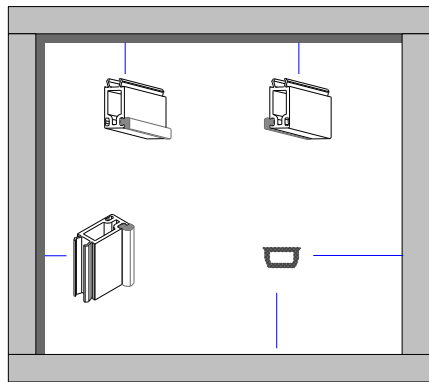
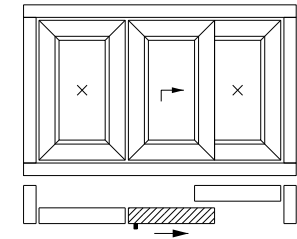

SCHEMA A

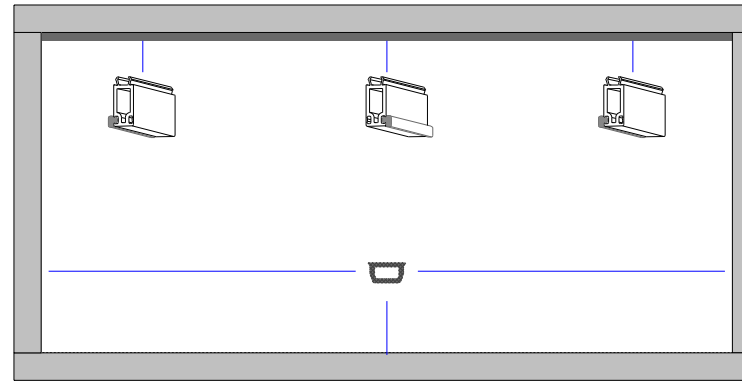
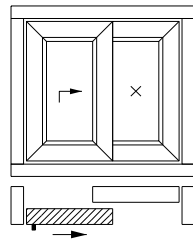

SCHEMA C

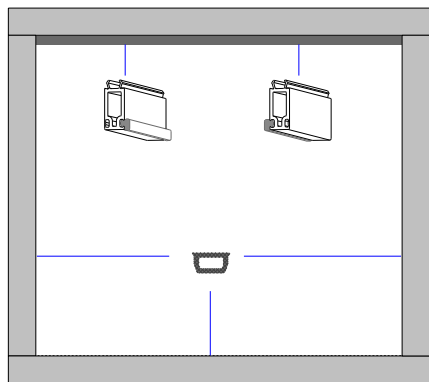
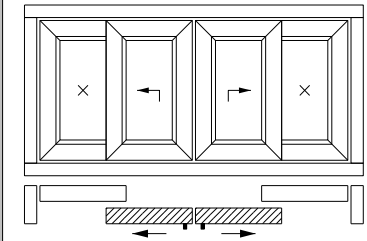

SCHEMA D

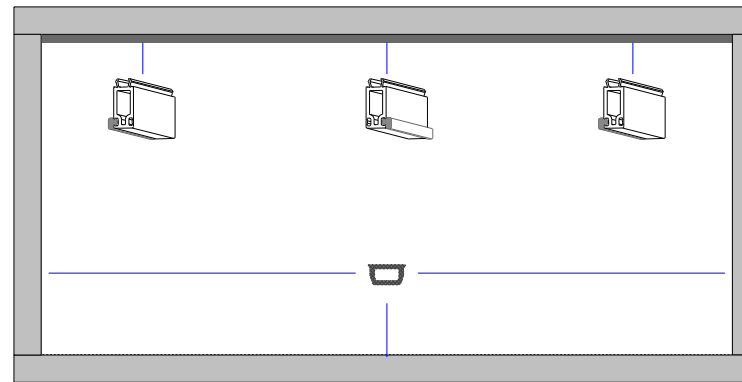
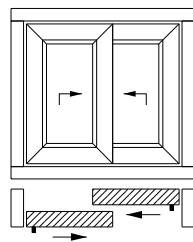

SCHEMA F

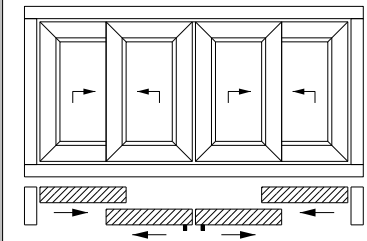

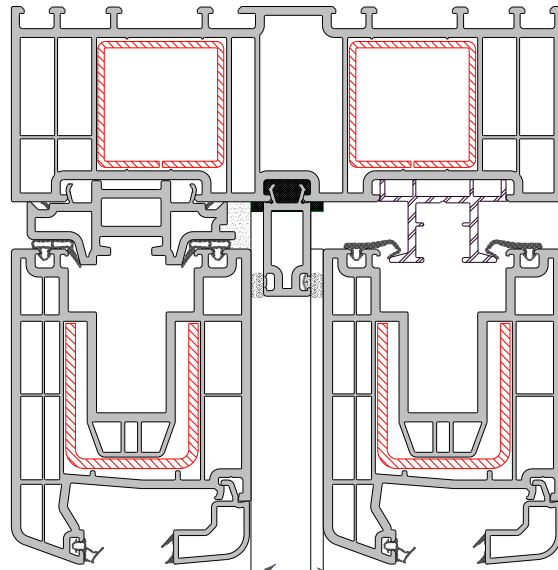
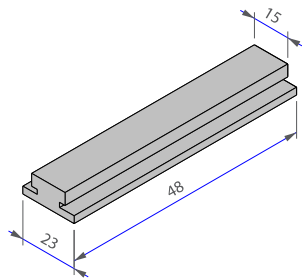
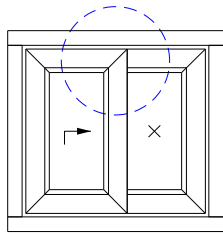

12424 - HS76 Interlock

12424 - HS76 Interlock

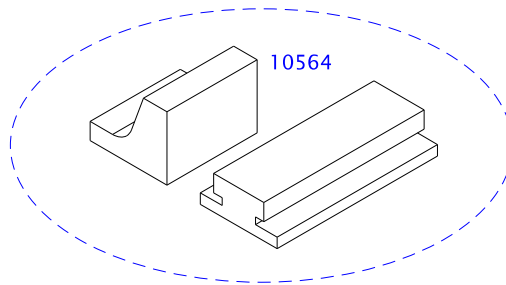

10564

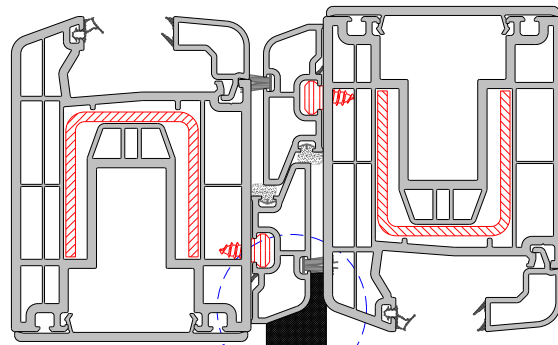
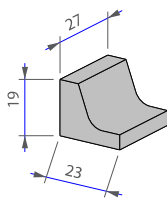
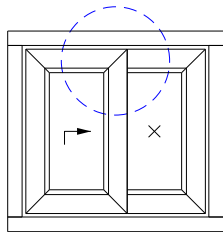

12423

Must be glued

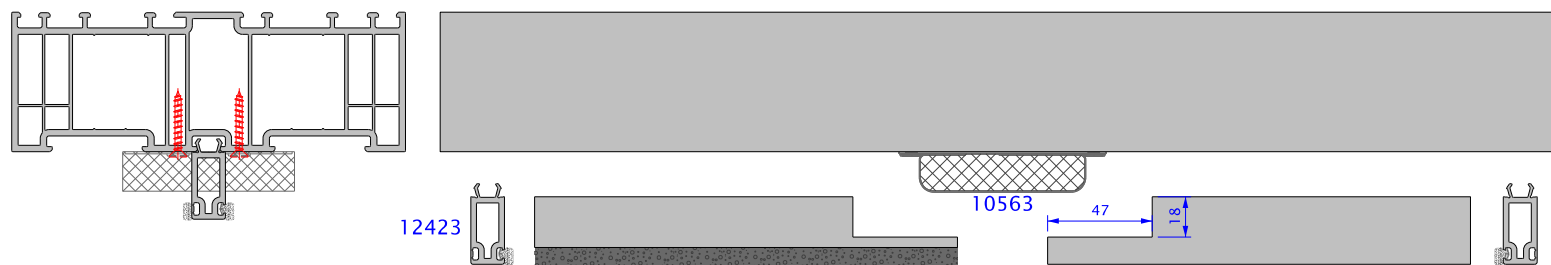
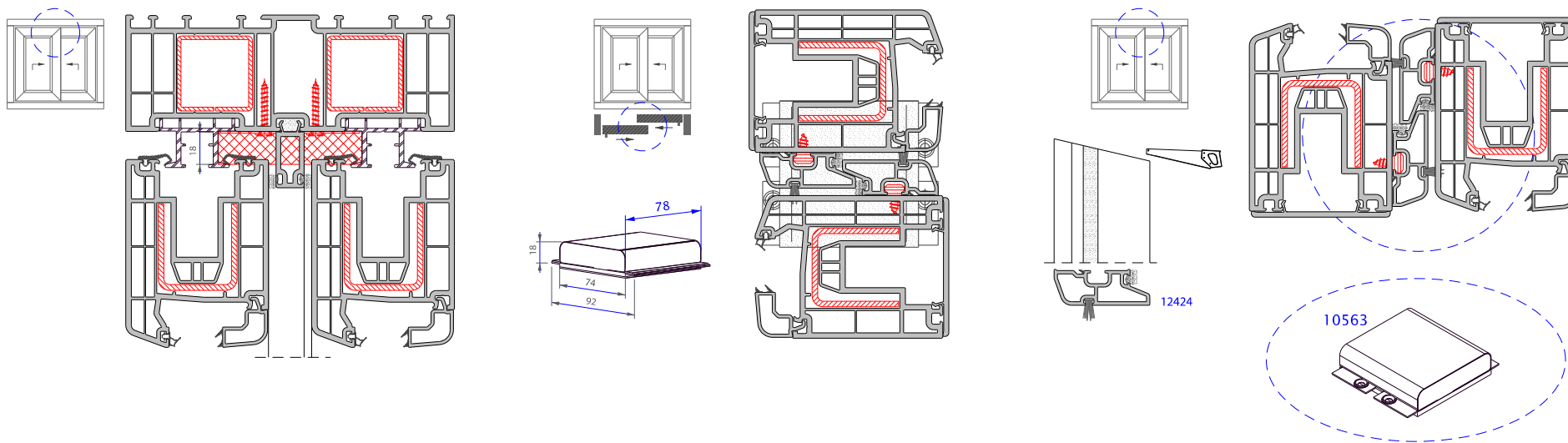

12423 – Mid Closing Profile must be milled and combined at the middle that is given in the drawings

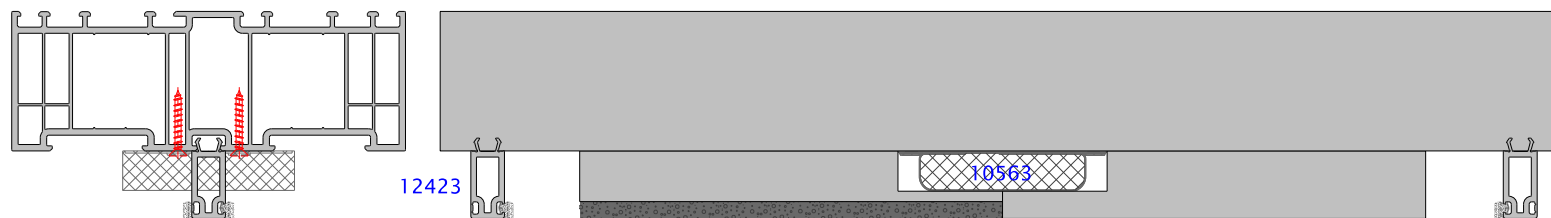

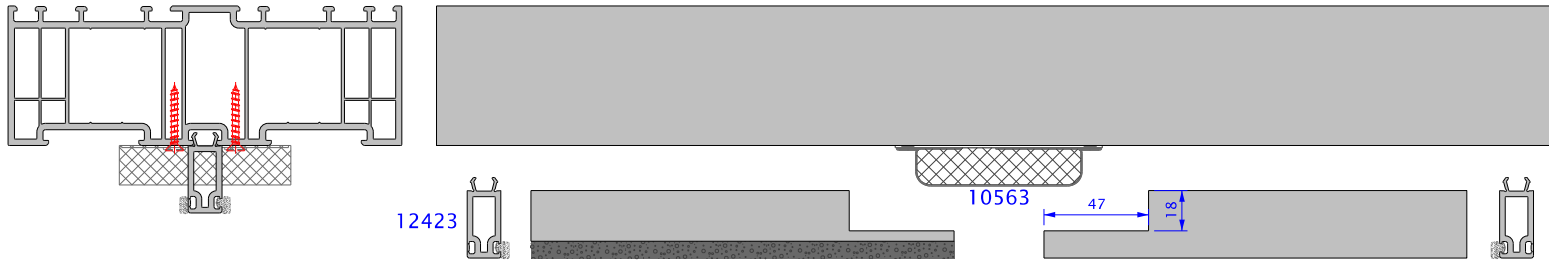

12423

10563

10563

12423– HS76 Middle Closing Profile must be milled as given in the figure



12423

10563

13107

In addition to this application, 13107 – HS76 Double Sash Mid Wedge is mounted over 12423 HS76 Mid Closing Profile. The detailed application method is given in the drawings. This application provides to increase insulation of double opening types in HS76.

13107 – HS Double Sash Mid. Wedge is also used double opening applicaiton.

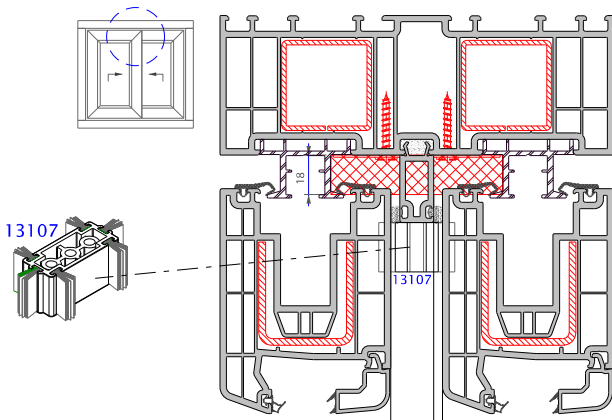

13107

13107

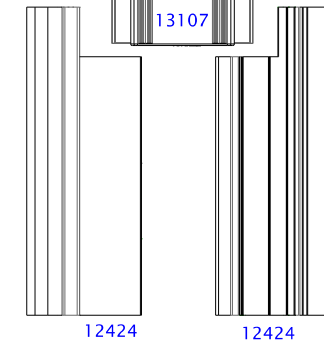

12424

12424

22

22

27.9

12424

12424

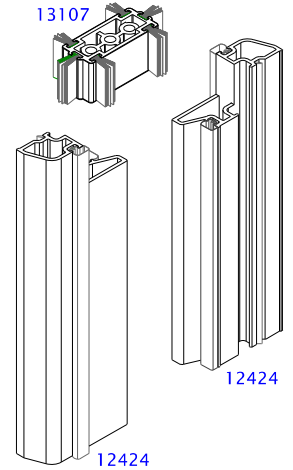

13107

12424

12424

13107

Installation of Additional Architrave (12427)

- * As a first step additional architrave must be mounted after the fabrication of HS76 frame.
- * 2.5 mm diameter drill must be used for clips drilling point.
- * Clips drilling point must be screwed as given in the drawings with spacing of 400 mm
- * Clips Screw (933) must be installed in the clips screw holes.
- * Frame Add. Architrave is cut as 2 vertical and 1 horizontal. The connection corners must be cut 45°.
- * After the all processes are done for HS76 window, architrave is mounted on the frame.
- * Architrave is an optional profile. Manufacturer can mount both side of the frame (inside & outside)

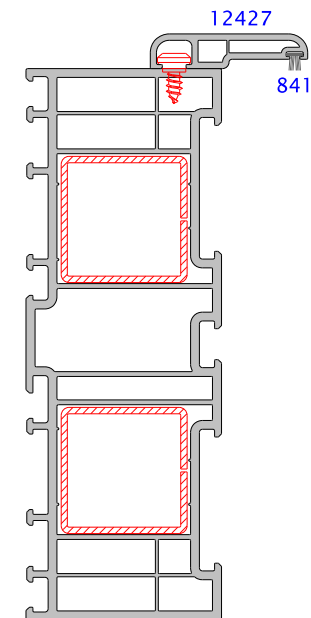
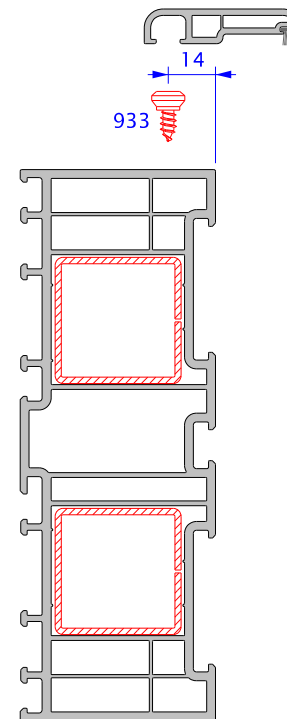
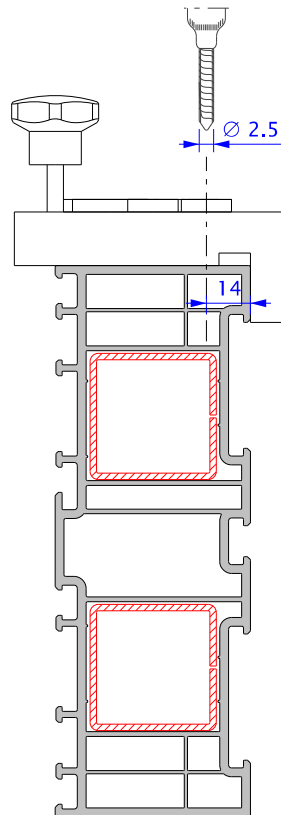
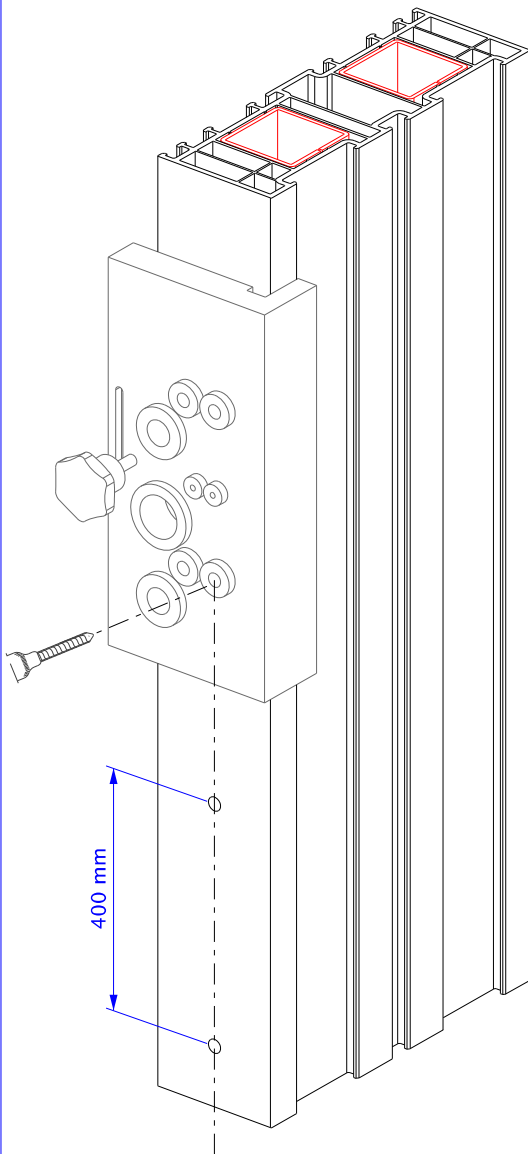
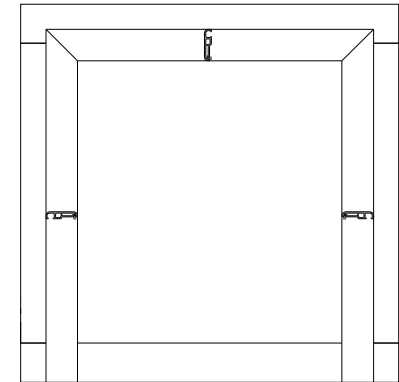

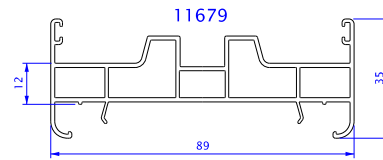

12420

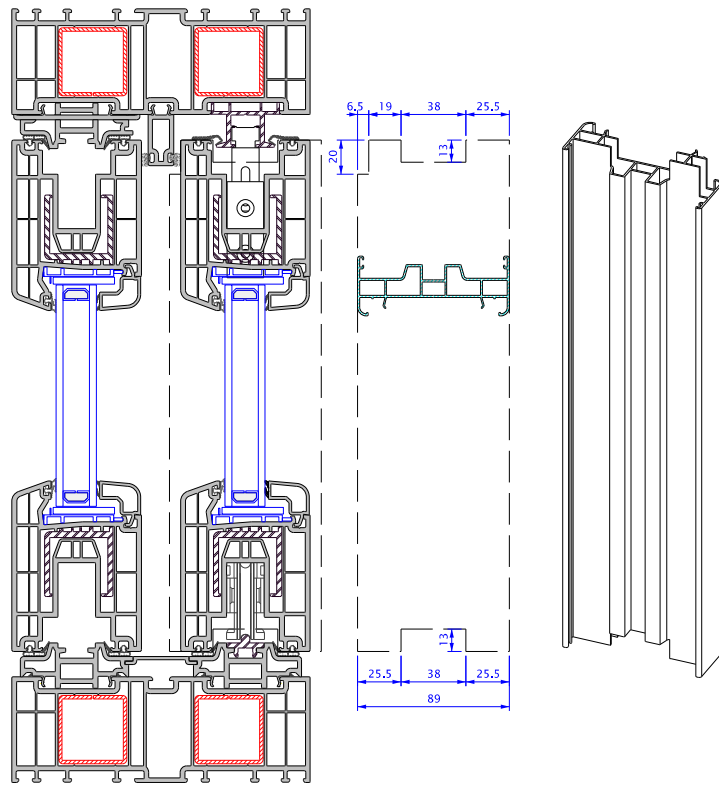

11680

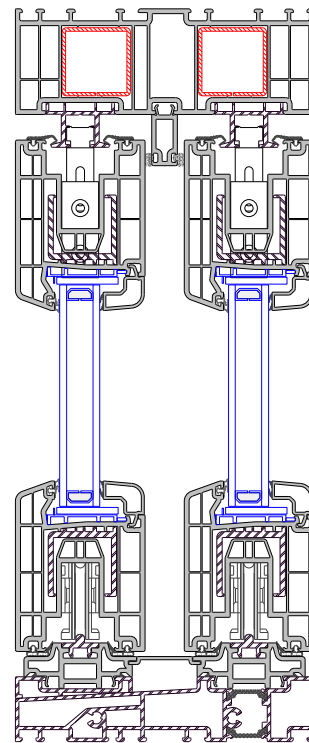

11678

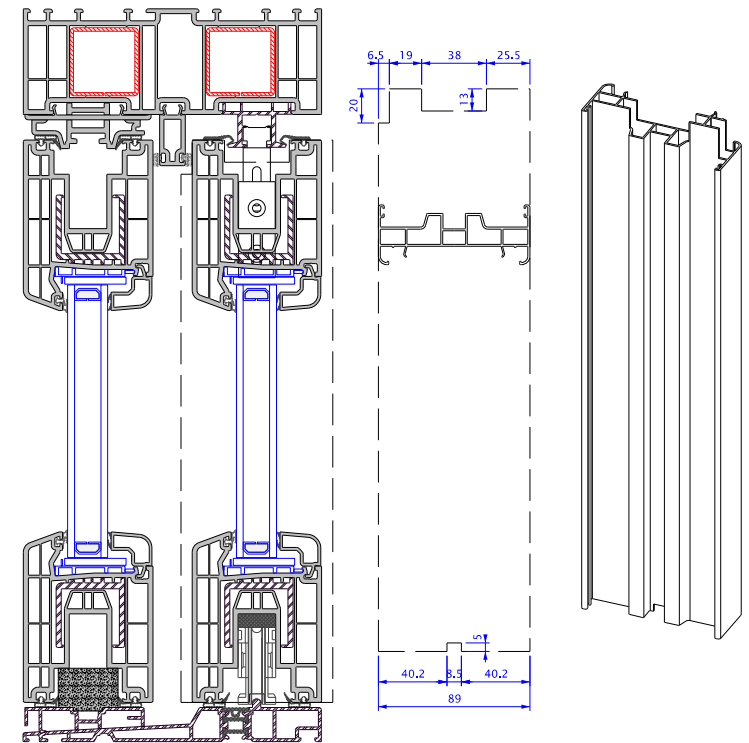

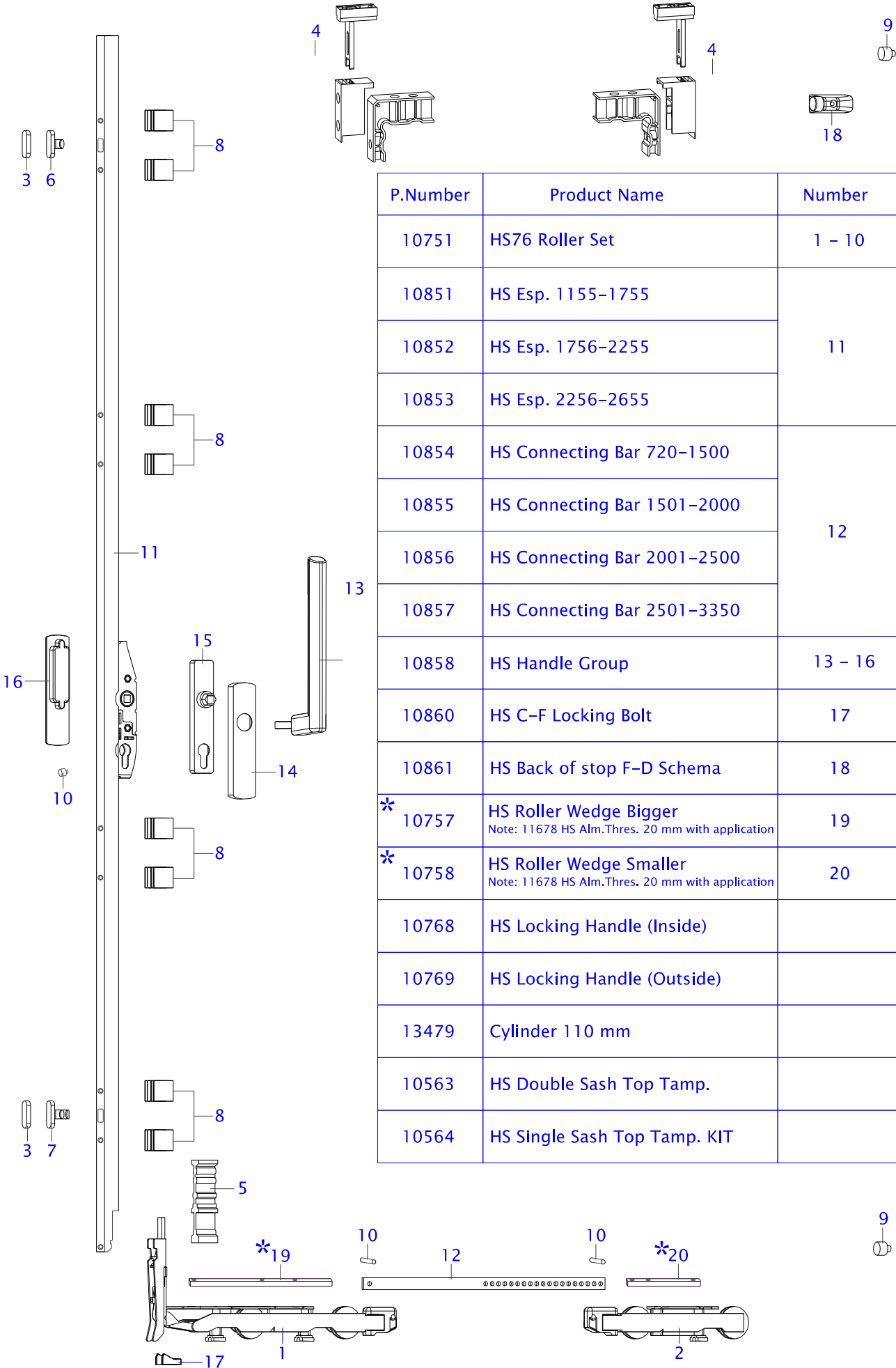

P.Number	Product Name	Number
10751	HS76 Roller Set	1 – 10
10851	HS Esp. 1155–1755	11
10852	HS Esp. 1756–2255	
10853	HS Esp. 2256–2655	
10854	HS Connecting Bar 720–1500	12
10855	HS Connecting Bar 1501–2000	
10856	HS Connecting Bar 2001–2500	
10857	HS Connecting Bar 2501–3350	
10858	HS Handle Group	13 – 16
10860	HS C-F Locking Bolt	17
10861	HS Back of stop F-D Schema	18
* 10757	HS Roller Wedge Bigger <small>Note: 11678 HS Alm.Thres. 20 mm with application</small>	19
* 10758	HS Roller Wedge Smaller <small>Note: 11678 HS Alm.Thres. 20 mm with application</small>	20
10768	HS Locking Handle (Inside)	
10769	HS Locking Handle (Outside)	
13479	Cylinder 110 mm	
10563	HS Double Sash Top Tamp.	
10564	HS Single Sash Top Tamp. KIT	

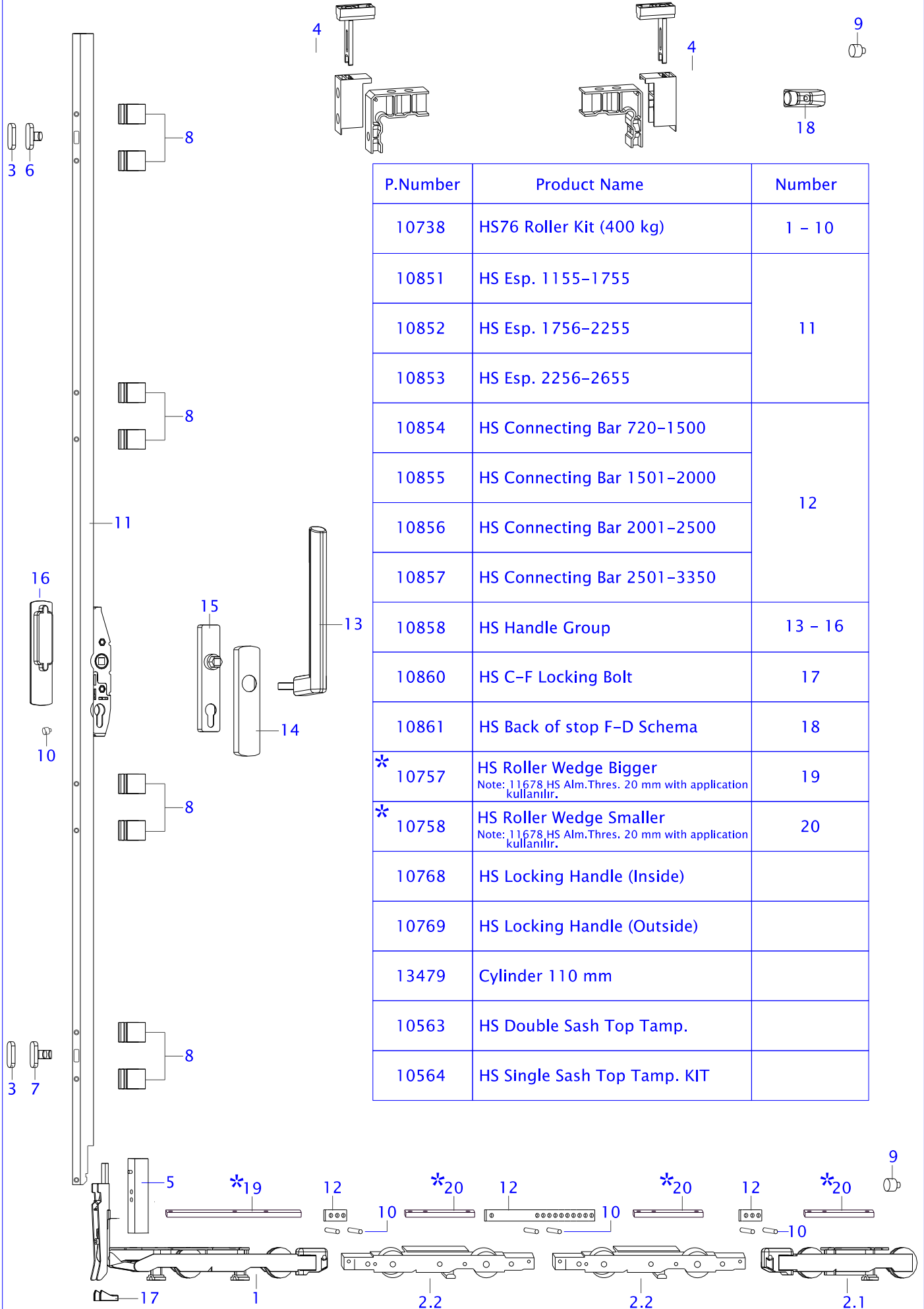

P.Number	Product Name	Number
10738	HS76 Roller Kit (400 kg)	1 – 10
10851	HS Esp. 1155–1755	11
10852	HS Esp. 1756–2255	
10853	HS Esp. 2256–2655	
10854	HS Connecting Bar 720–1500	
10855	HS Connecting Bar 1501–2000	12
10856	HS Connecting Bar 2001–2500	
10857	HS Connecting Bar 2501–3350	
10858	HS Handle Group	13 – 16
10860	HS C–F Locking Bolt	17
10861	HS Back of stop F–D Schema	18
* 10757	HS Roller Wedge Bigger <small>Note: 11678 HS Alm.Thres. 20 mm with application kullanılir.</small>	19
* 10758	HS Roller Wedge Smaller <small>Note: 11678 HS Alm.Thres. 20 mm with application kullanılir.</small>	20
10768	HS Locking Handle (Inside)	
10769	HS Locking Handle (Outside)	
13479	Cylinder 110 mm	
10563	HS Double Sash Top Tamp.	
10564	HS Single Sash Top Tamp. KIT	

Deceuninck has the rights to change this tec.doc without any prior notice

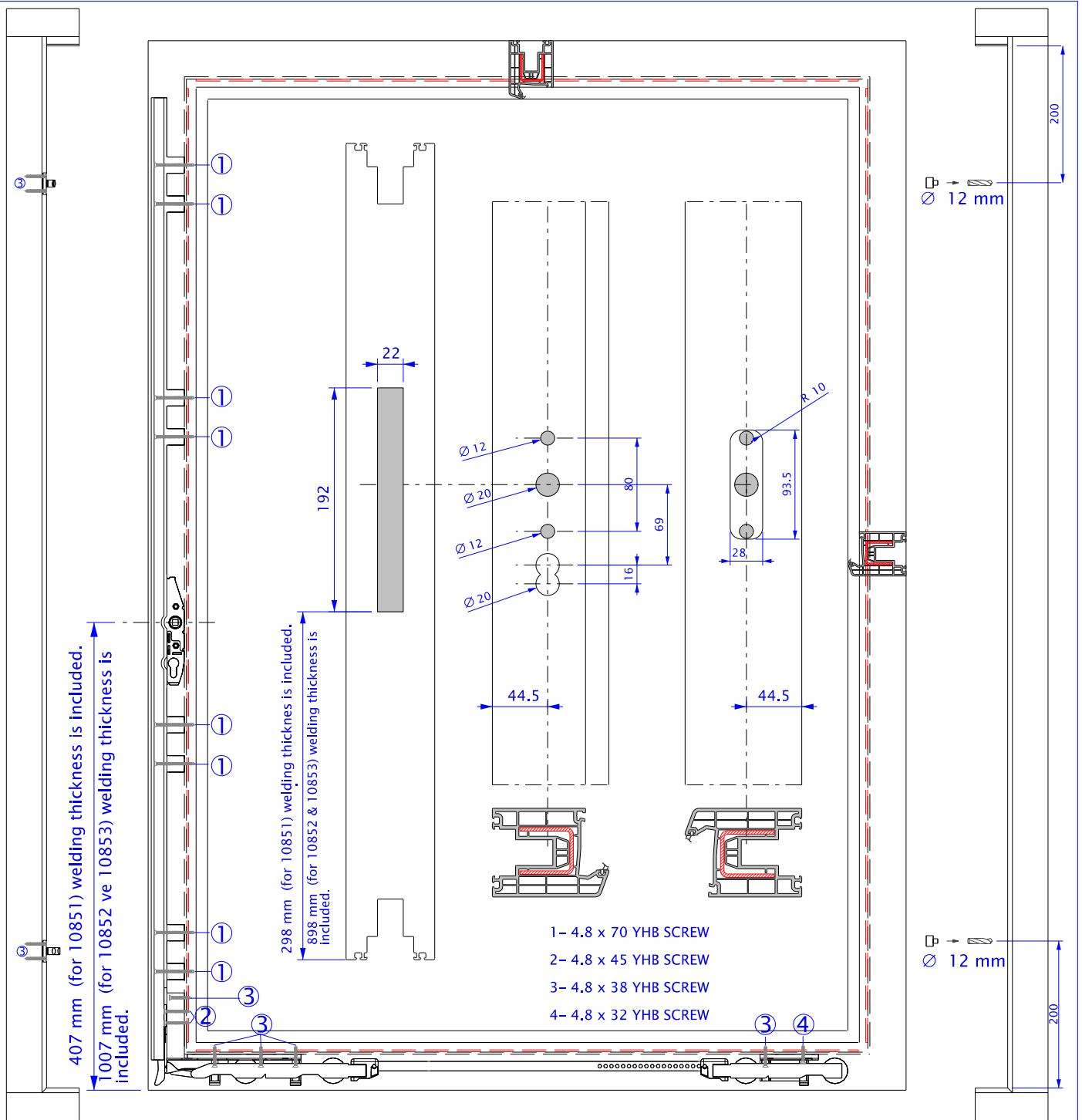

Cutting = HS Connecting Bar Length = Frame width - 670

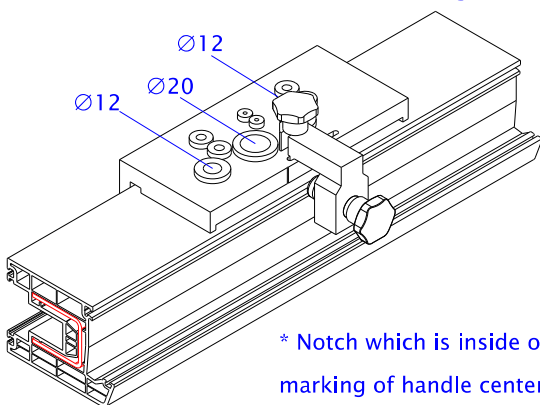

* Notch which is inside on the mounting apary and marking of handle center must be fitted each other

Example: Center of Handle 1007 mm

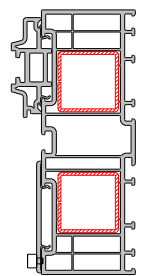
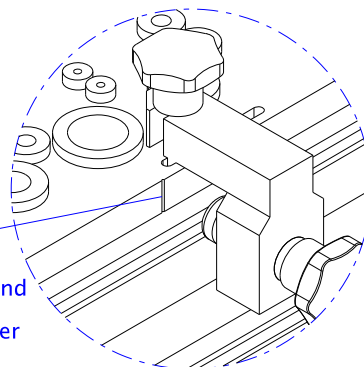

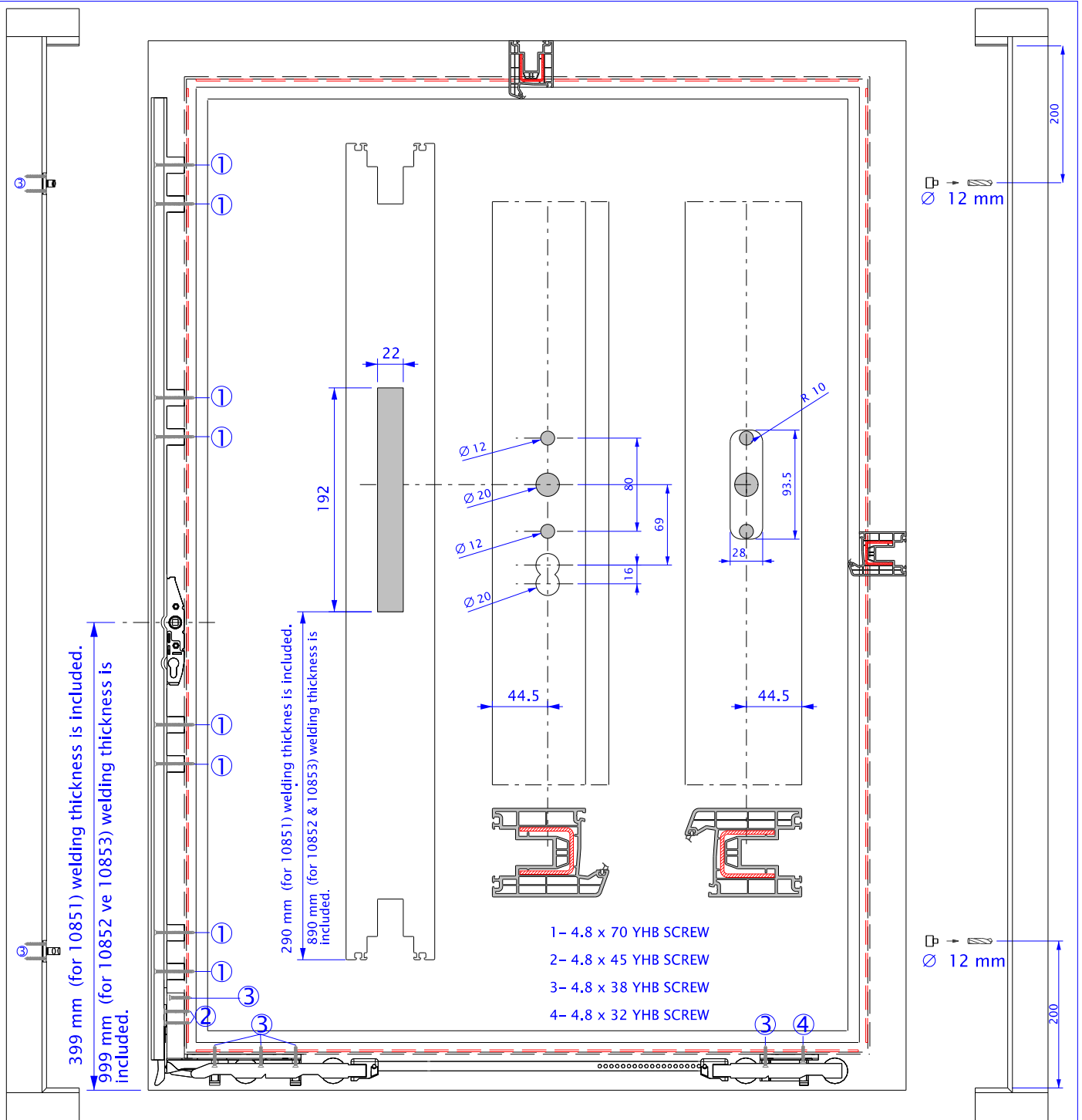

Cutting = HS Connecting Bar Length = Frame width - 670

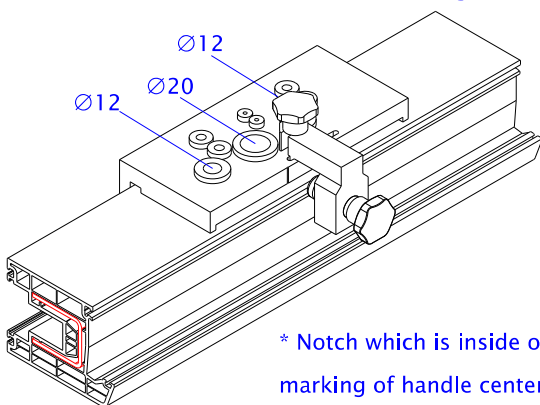

* Notch which is inside on the mounting apary and marking of handle center must be fitted each other

Example: Center of Handle 1007 mm

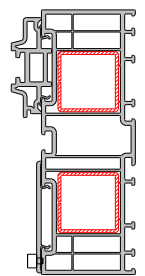
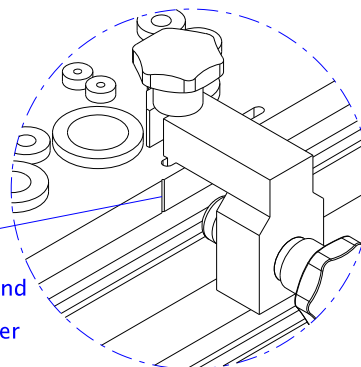

SCHEMA C

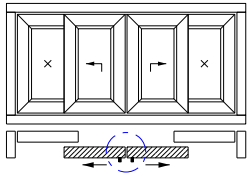

SCHEMA F

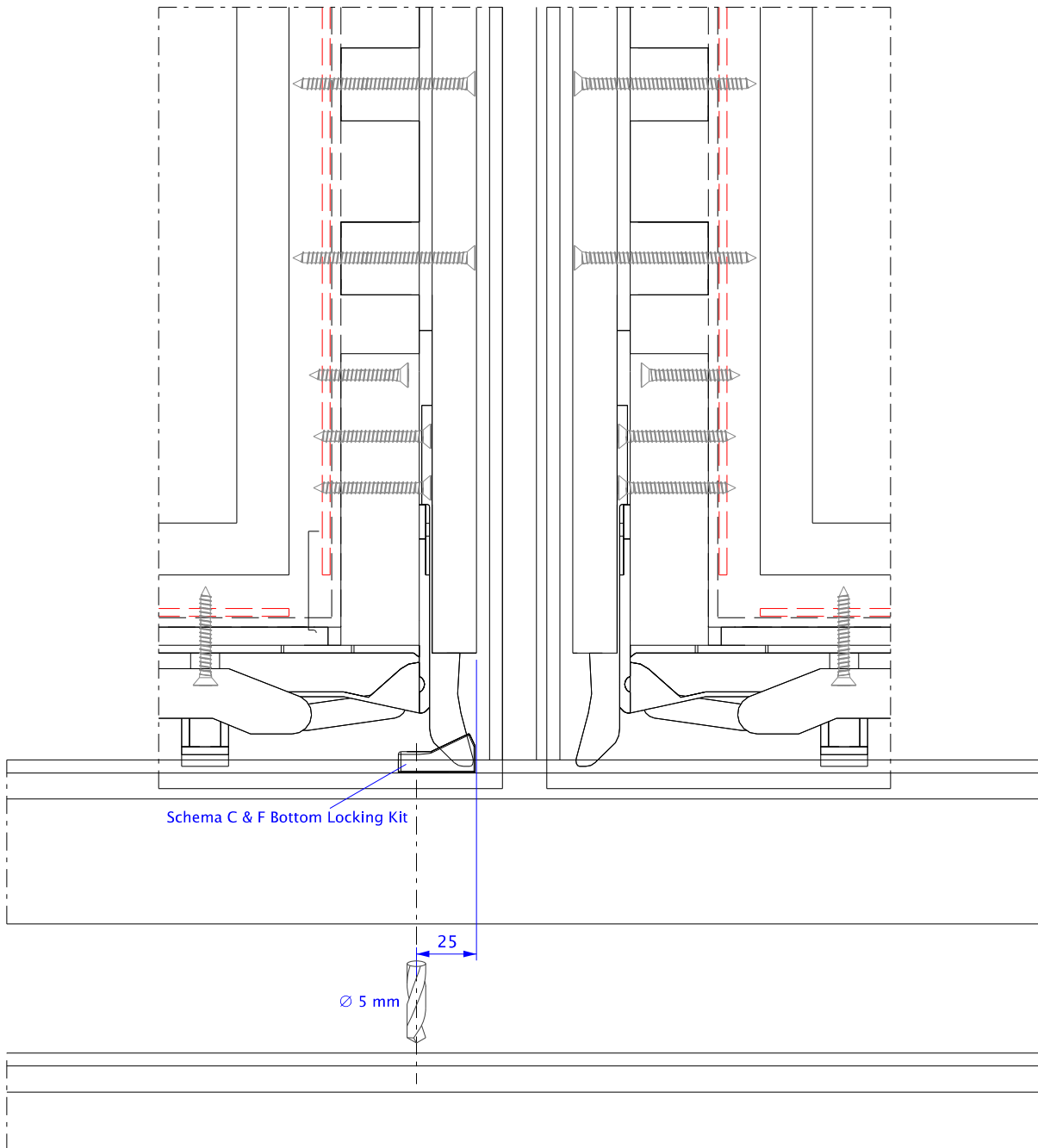
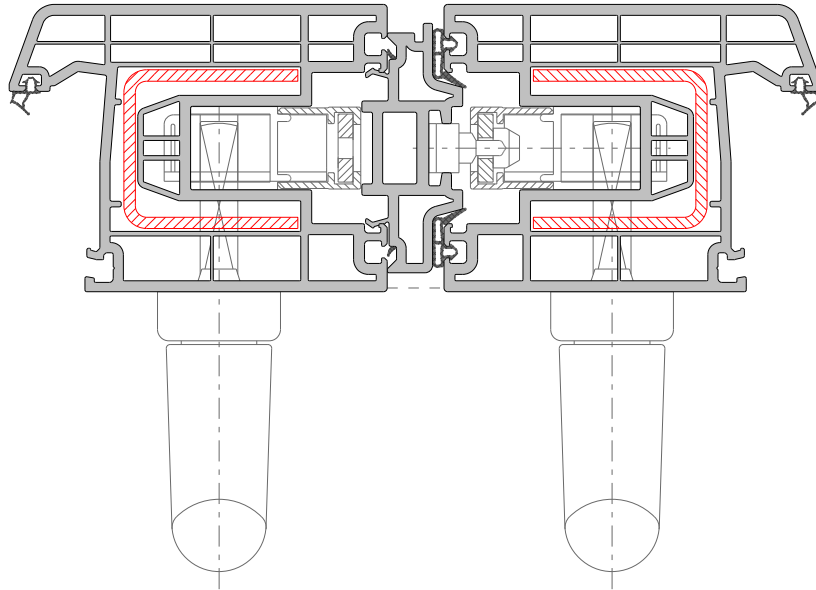
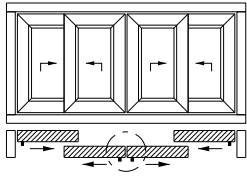

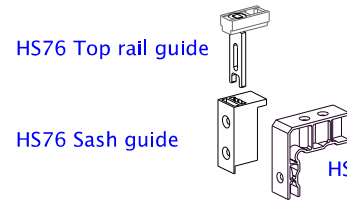
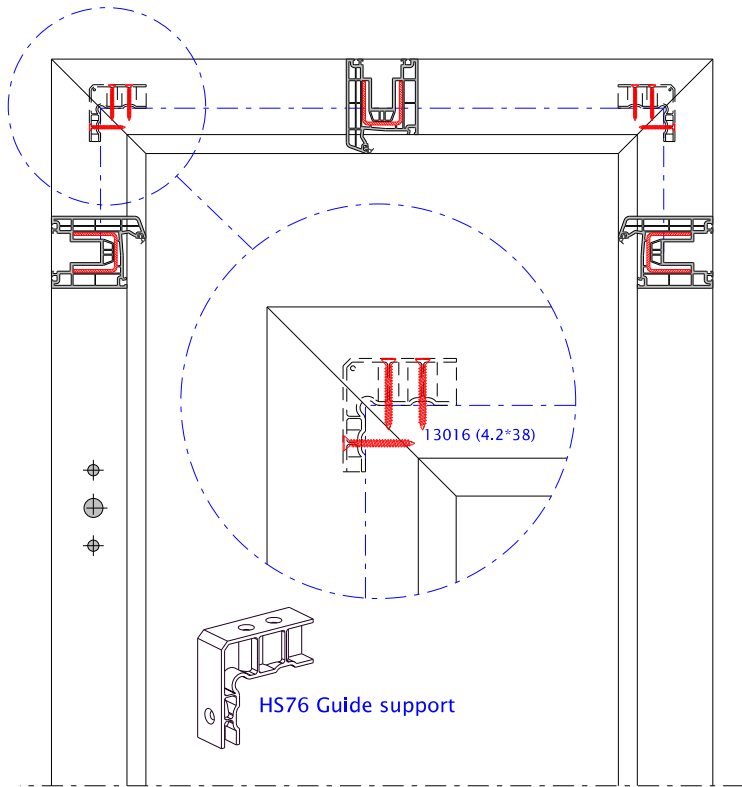

- * The movable sash that accessories fixed on it, is put on the frame
- * The sash guide is fixed on top rail guide than it is installed on the sash as shown,during this process the handle must be on locked position

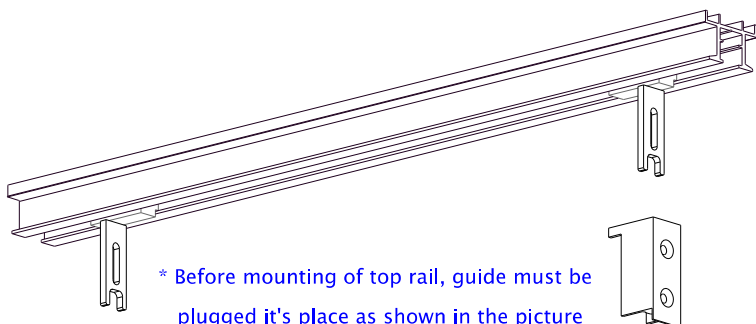
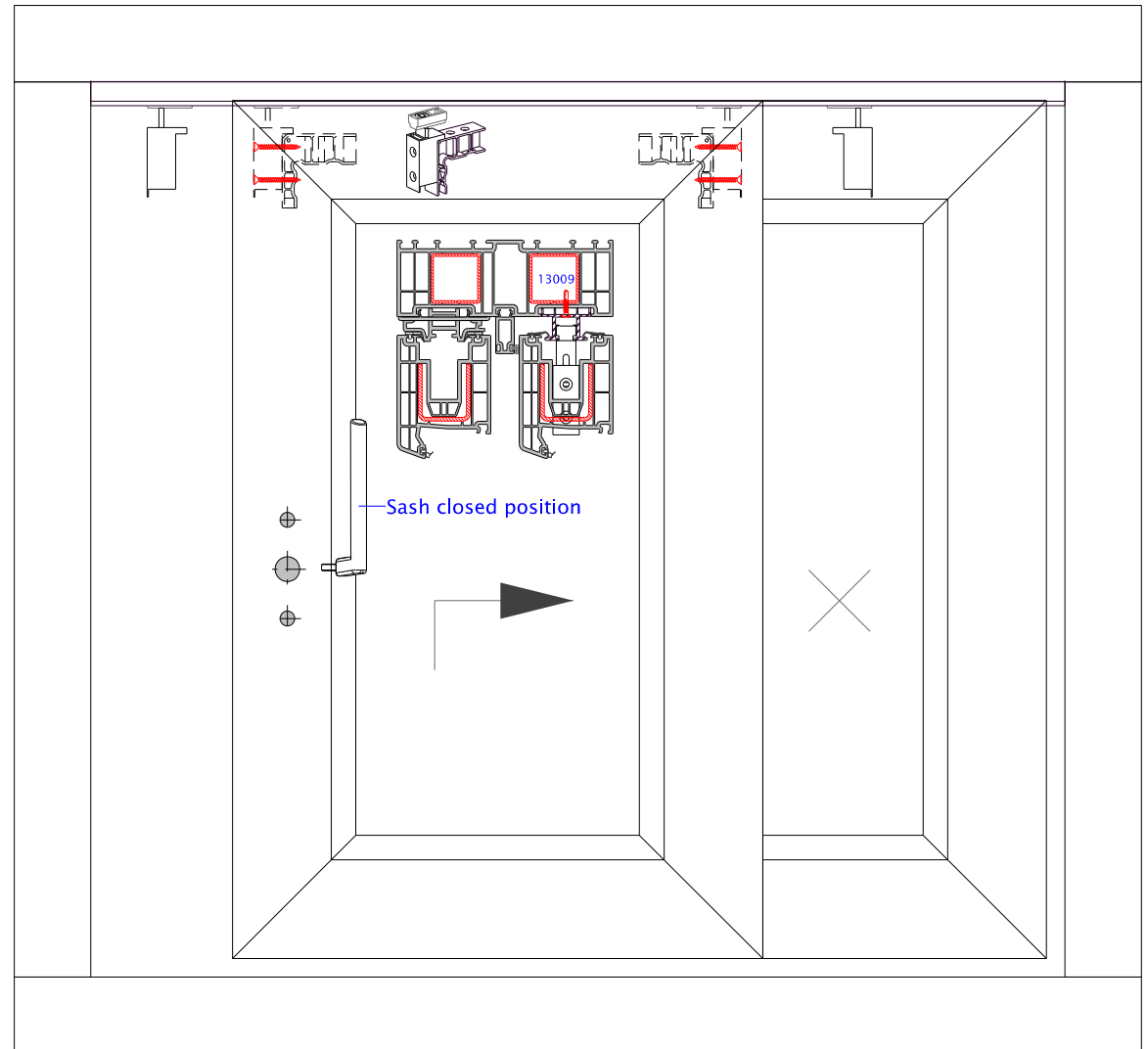

* Before mounting of top rail, guide must be plugged it's place as shown in the picture

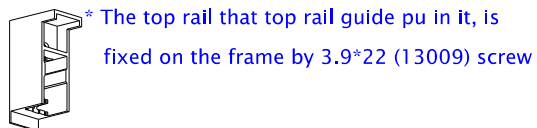

* The top rail that top rail guide pu in it, is fixed on the frame by 3.9*22 (13009) screw

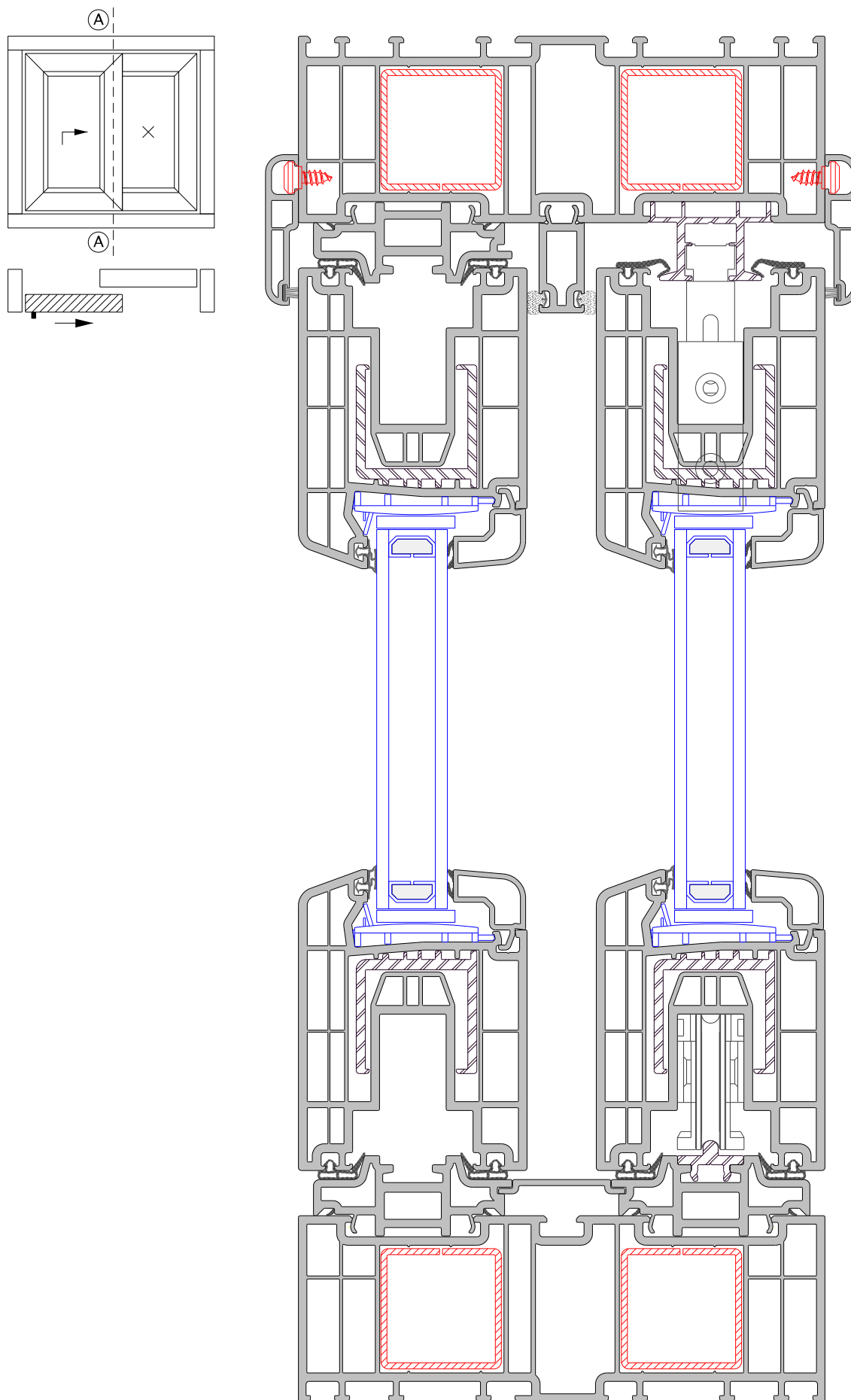

* As optional, 11467 can be used instead of 11685 that is shown in the details.

* Achitrave profile is an optional profile, it will be used according to request of customer.

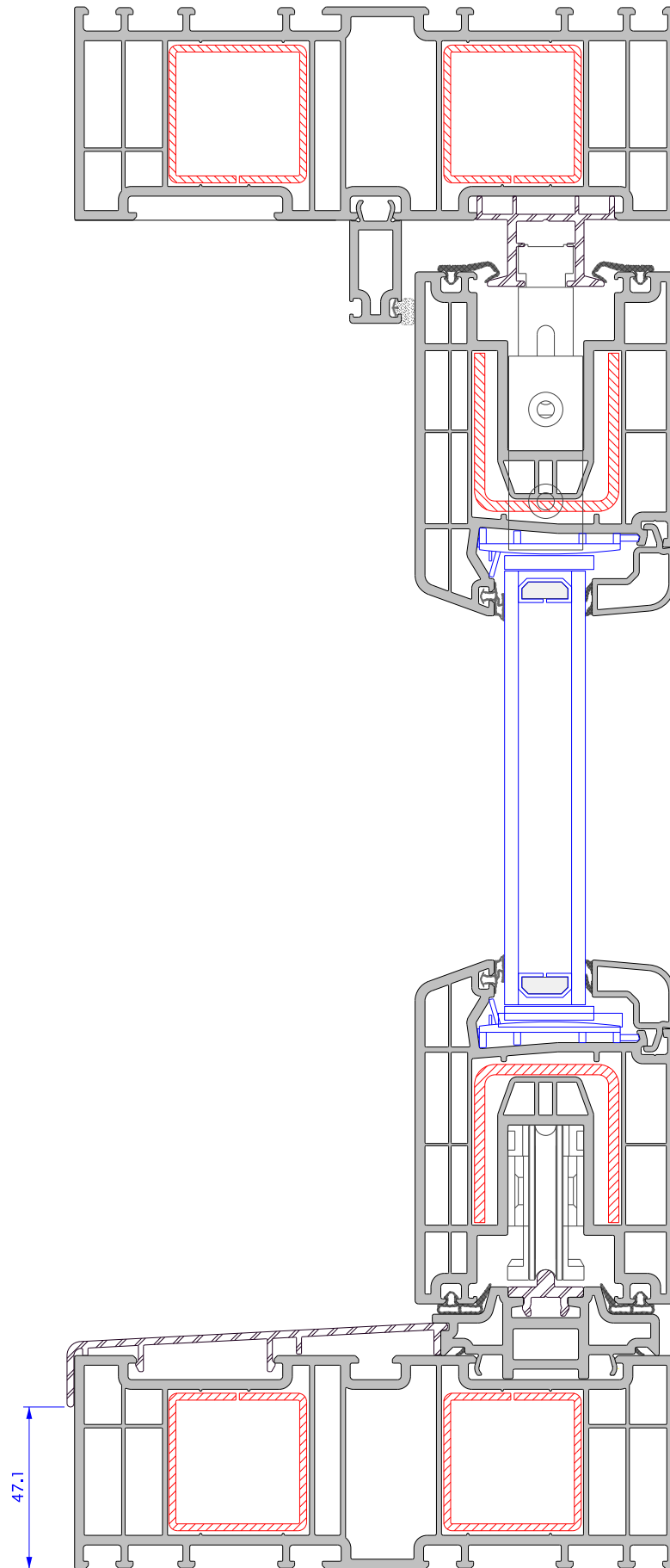
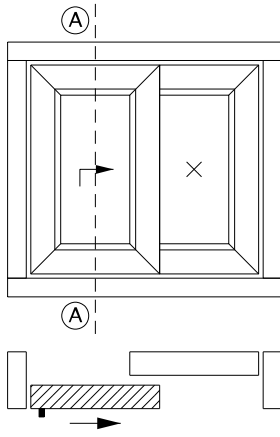

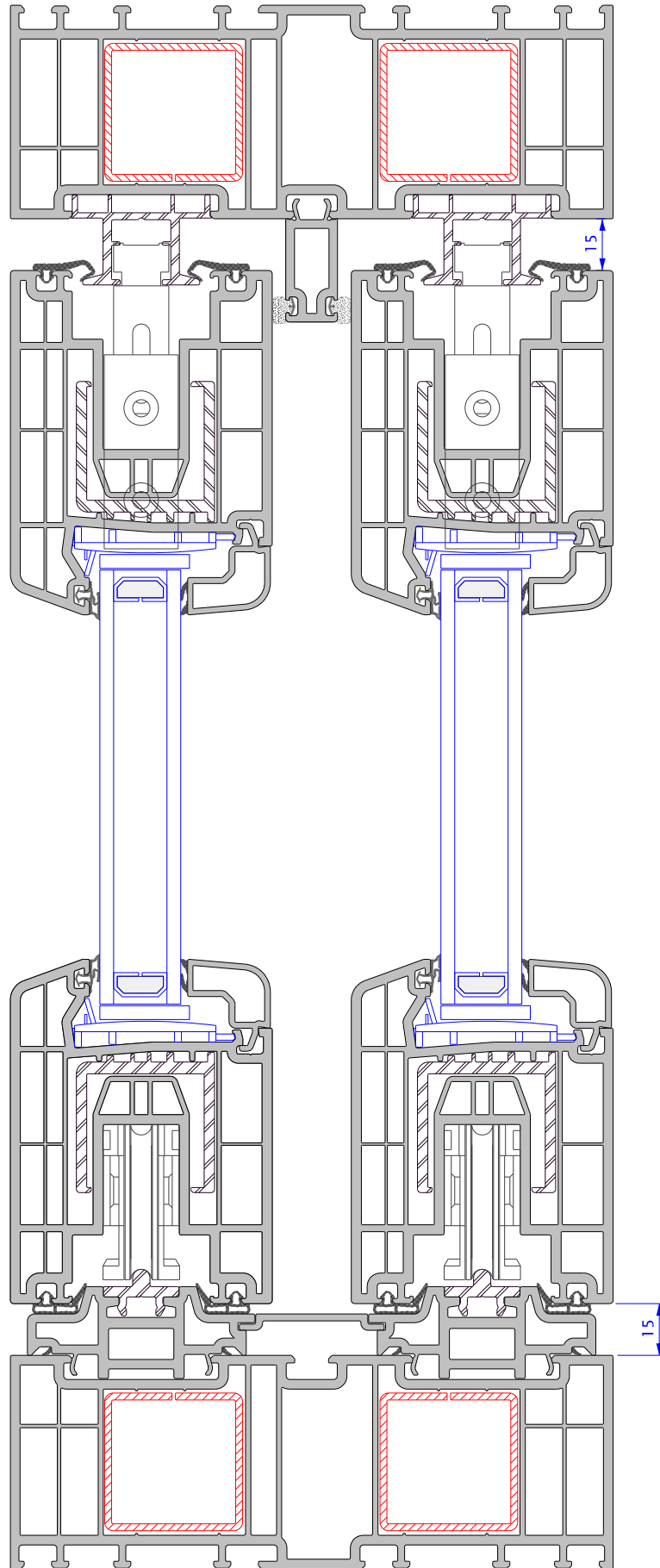
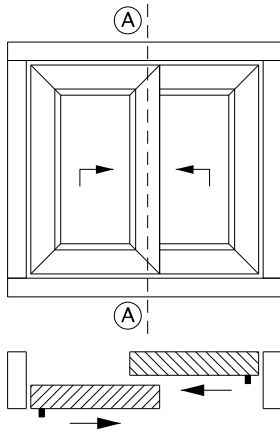

* As optional, 11467 can be used instead of 11685 that is shown in the details.

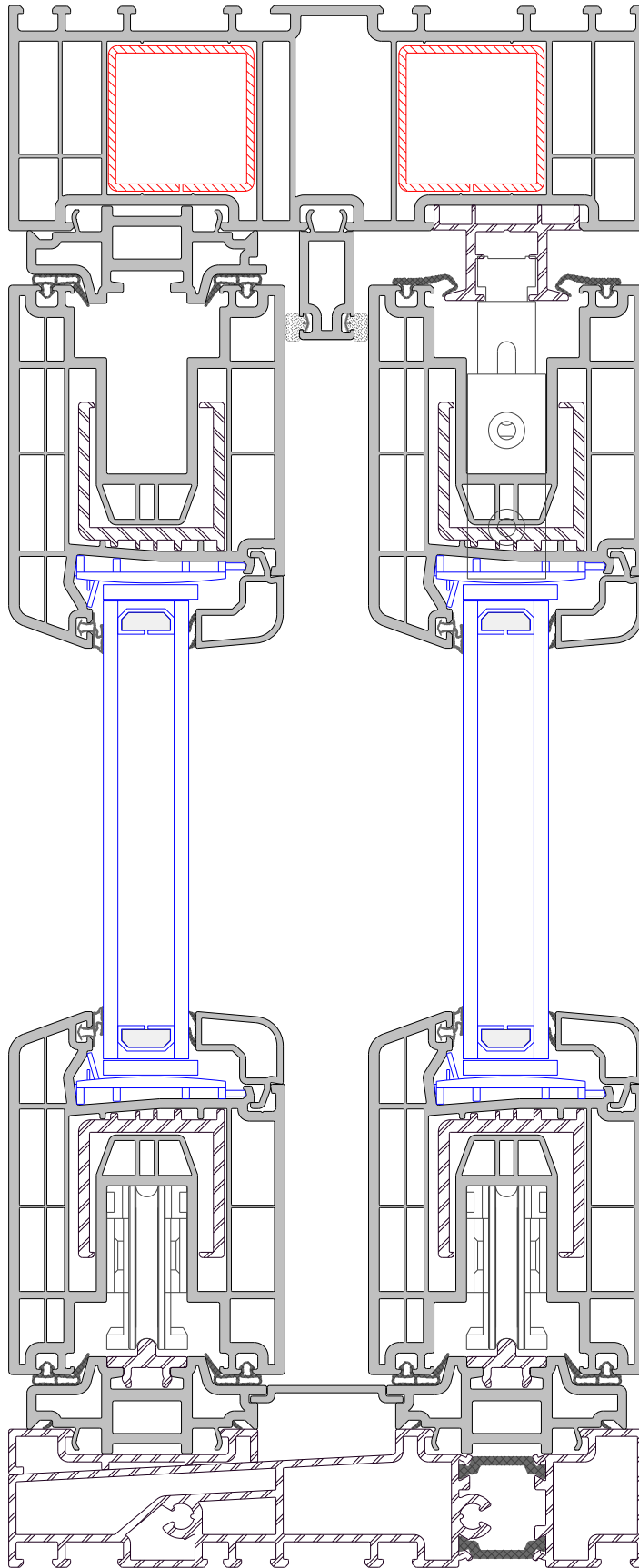
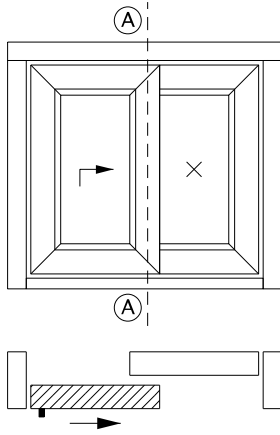

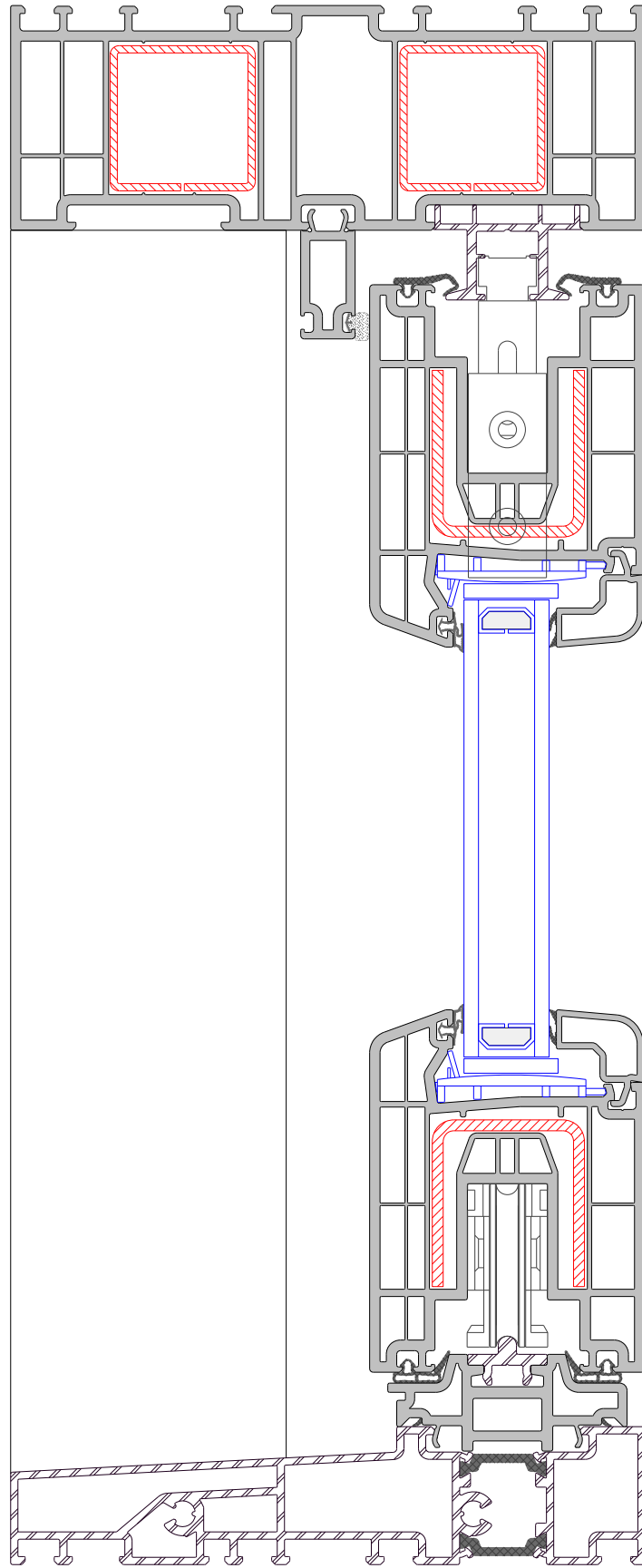
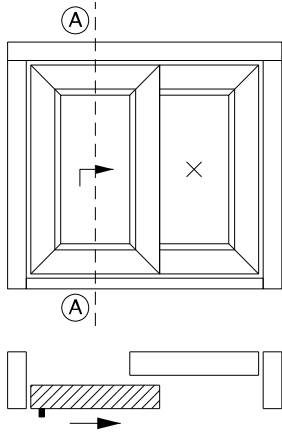

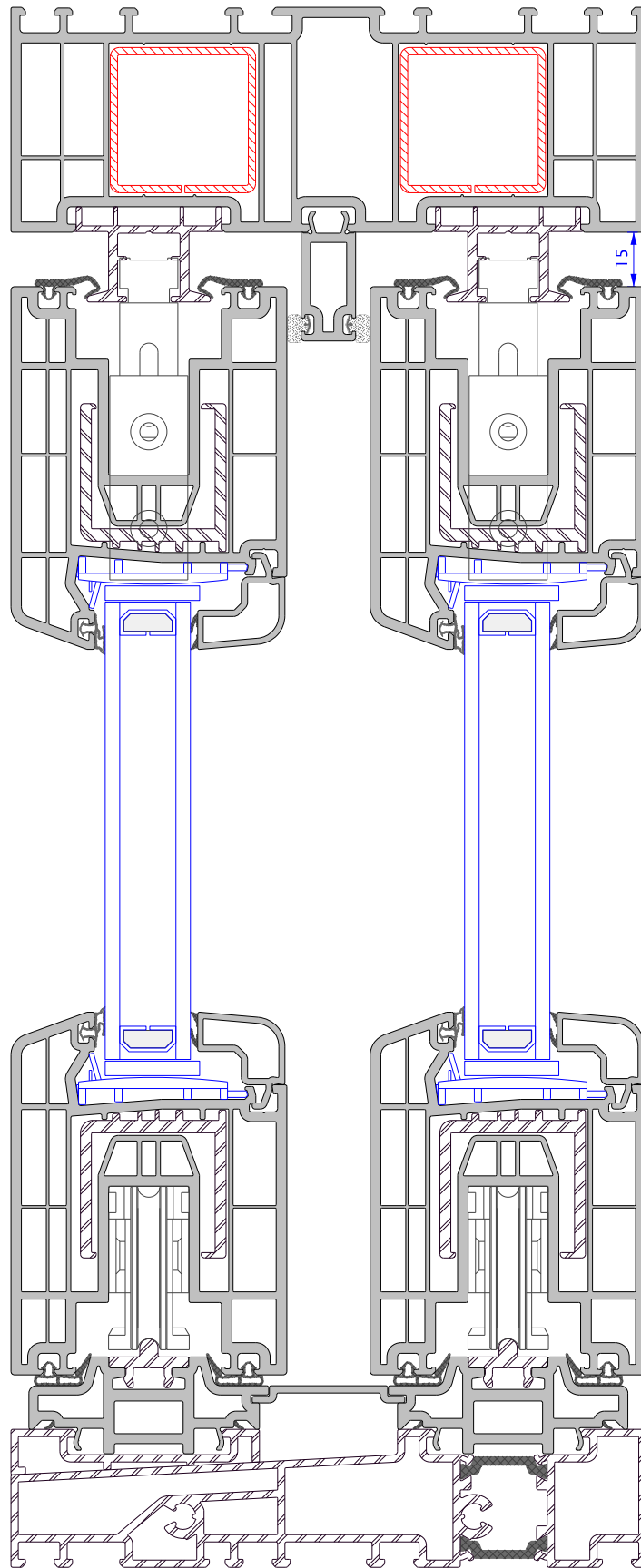
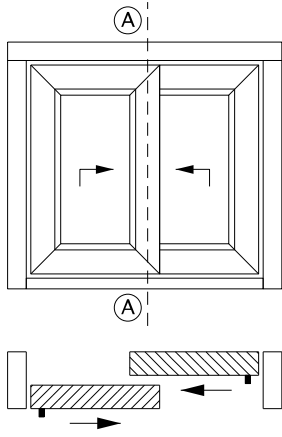

* As optional, 11467 can be used instead of 11685 that is shown in the details.

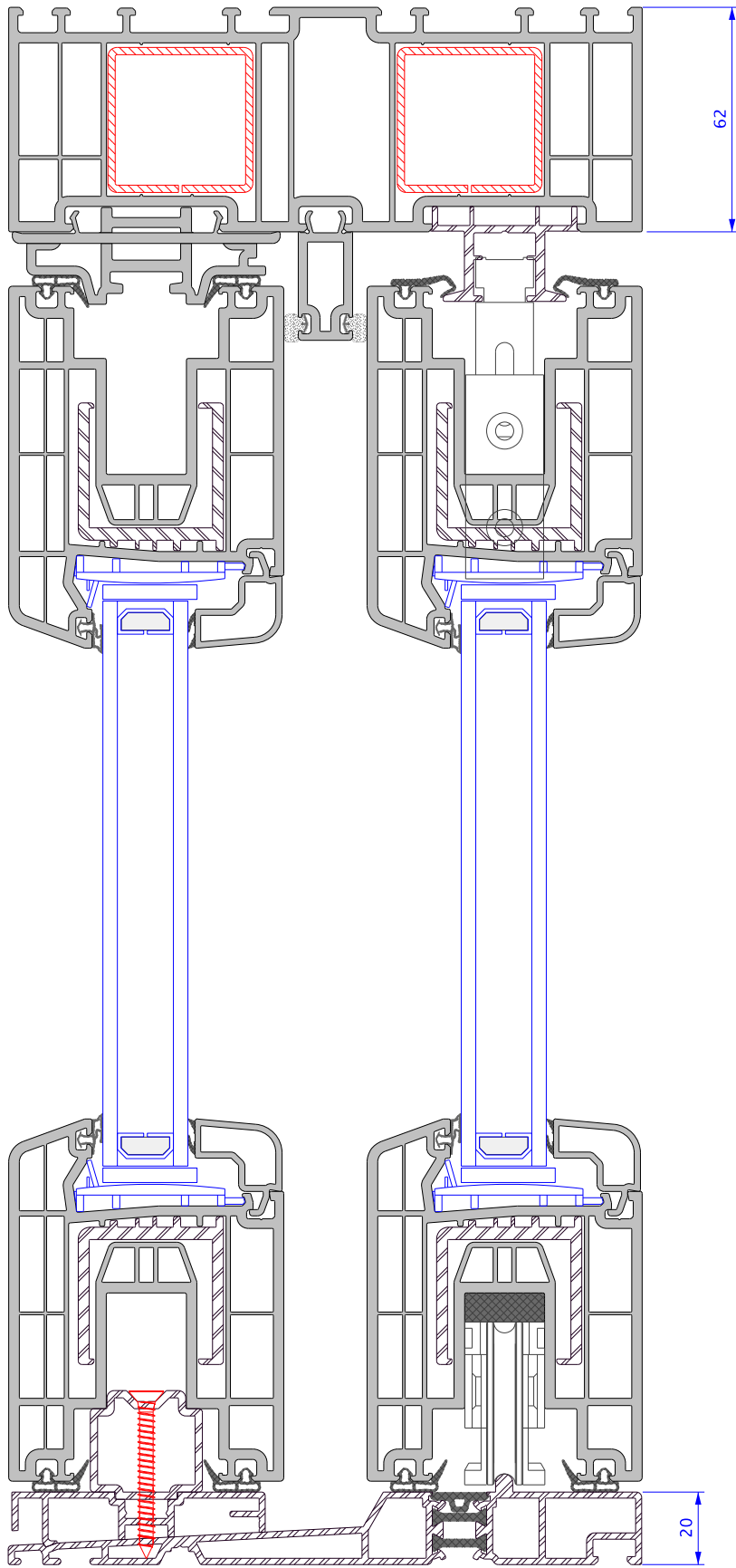
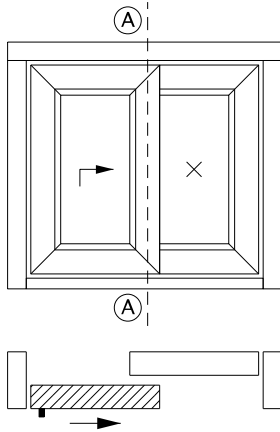

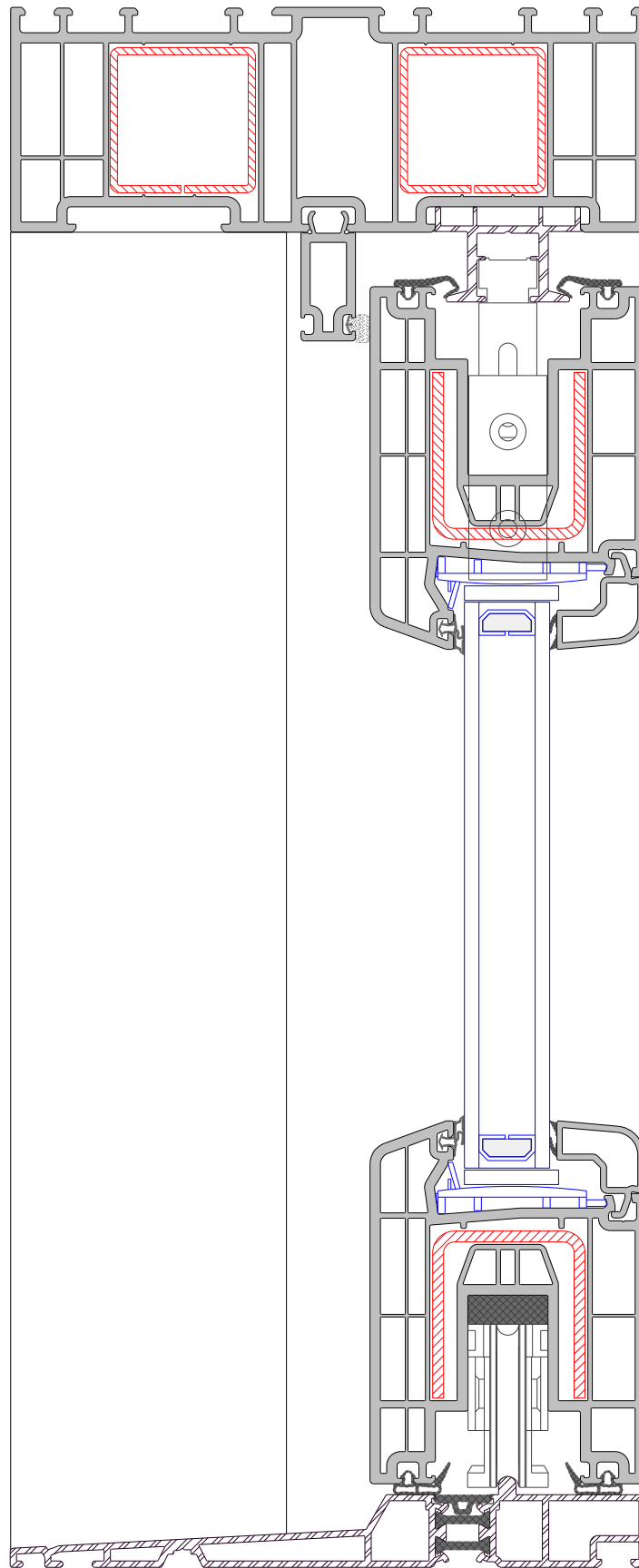
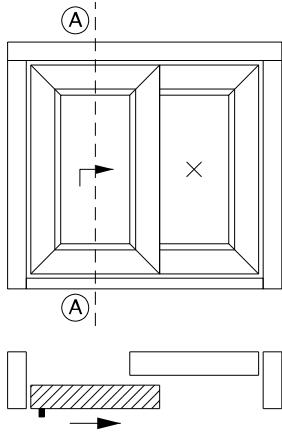

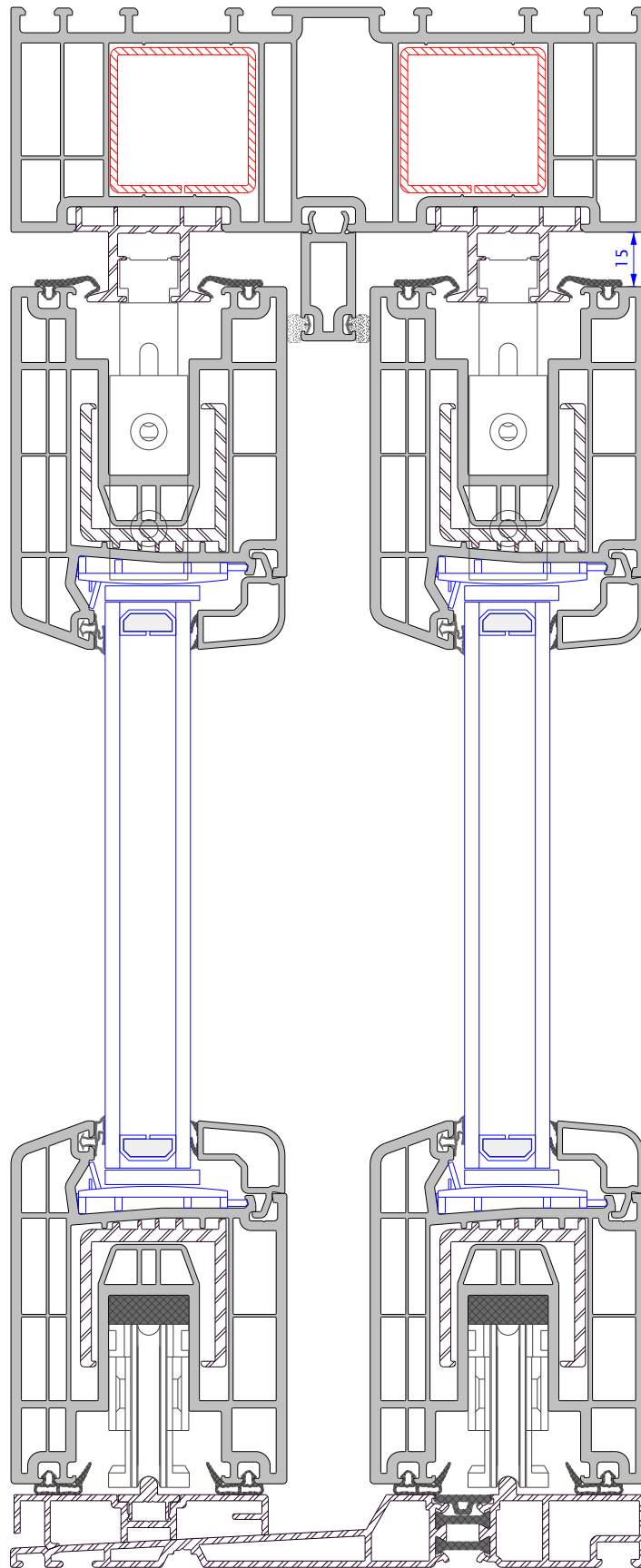
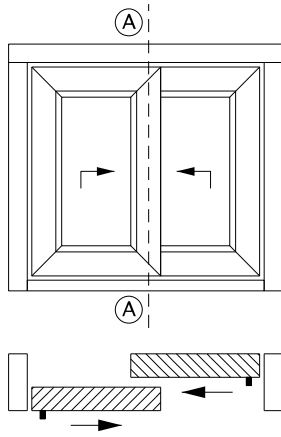

* As optional, 11467 can be used instead of 11685 that is shown in the details.

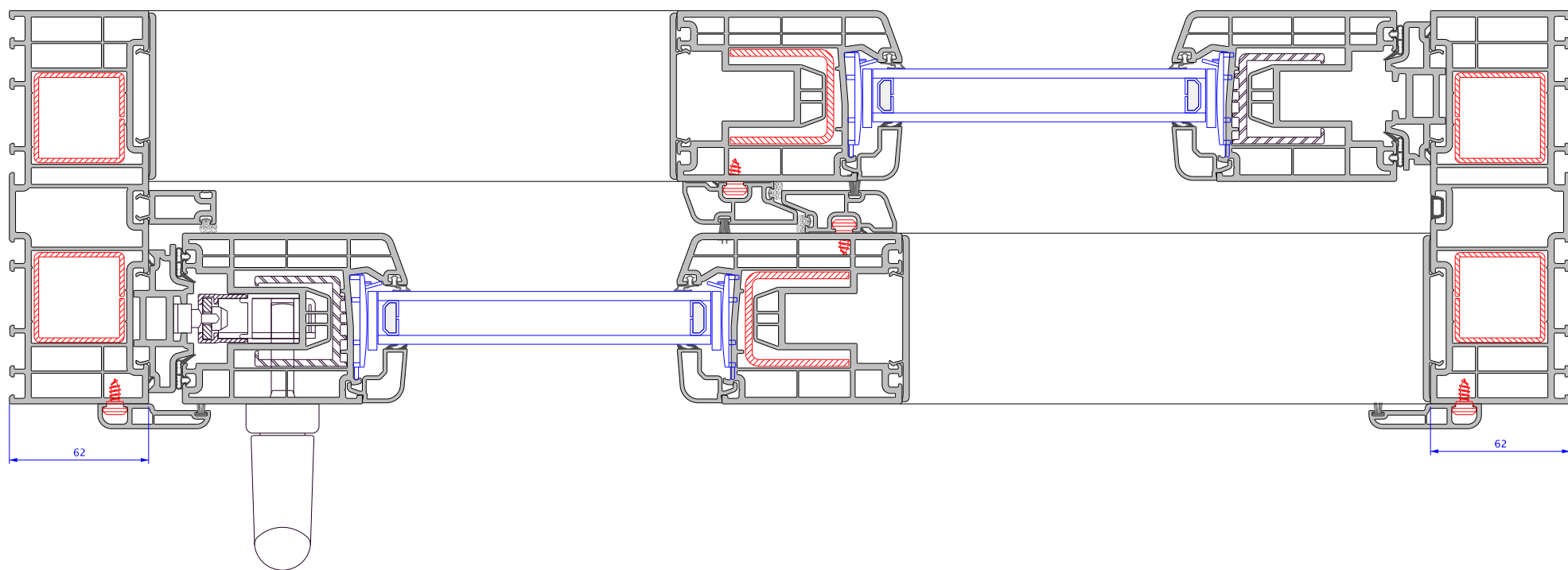
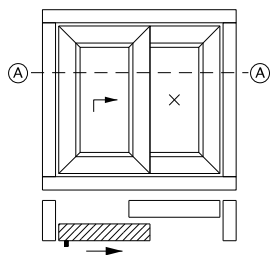

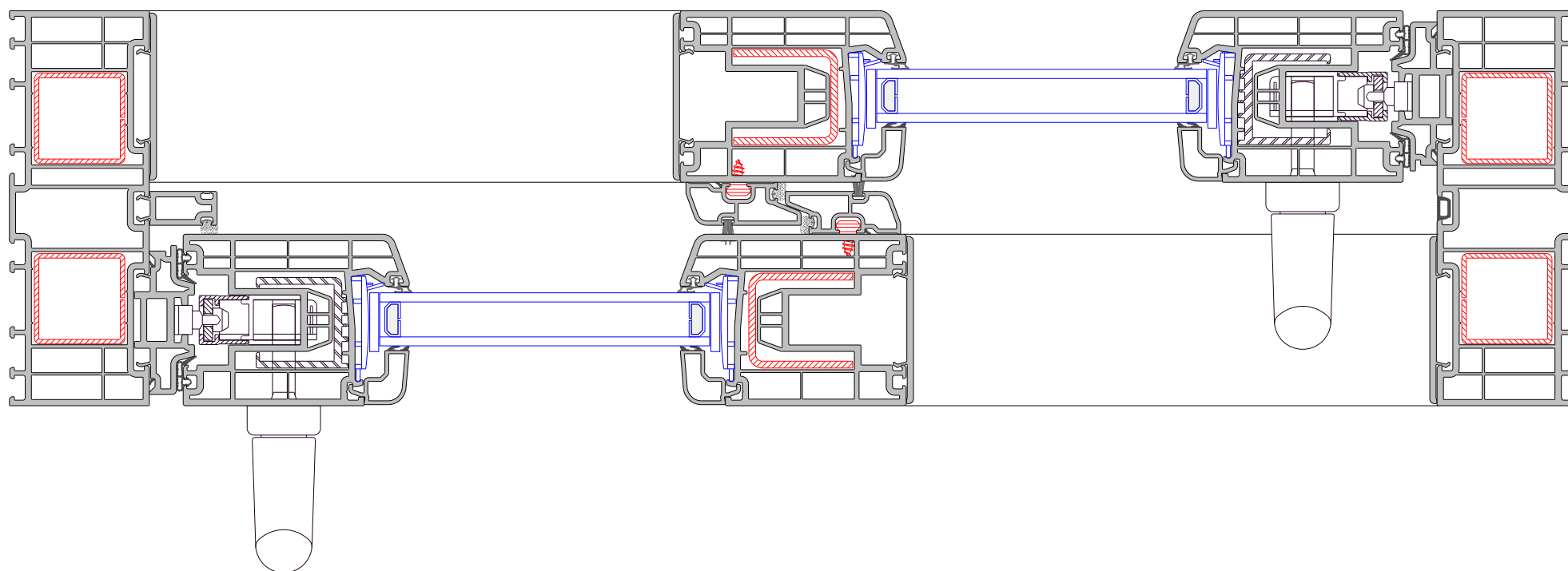
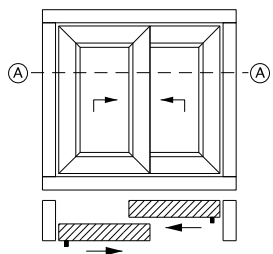

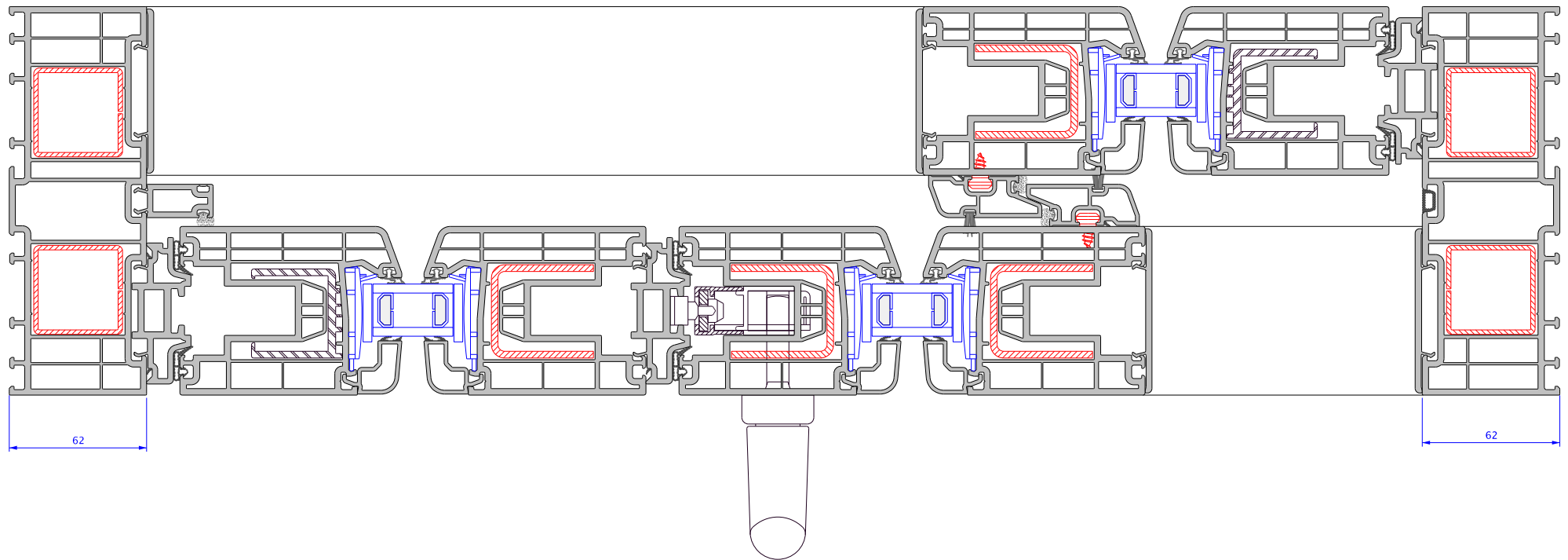
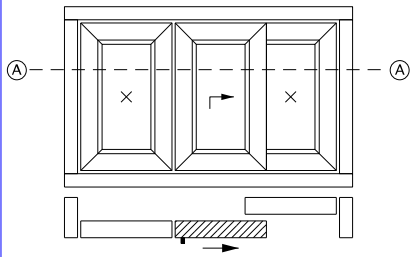

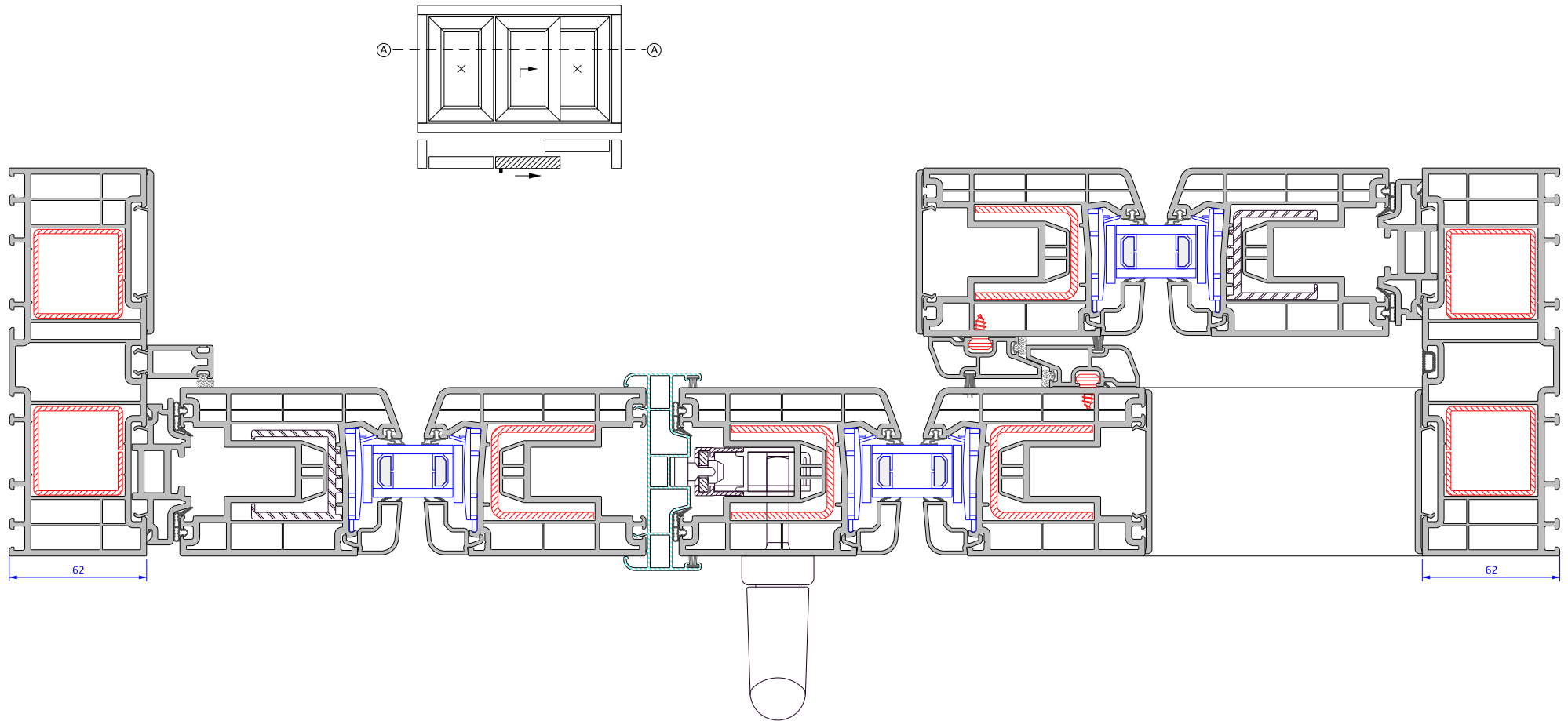

* As optional, 11467 can be used instead of 11685 that is shown in the details.

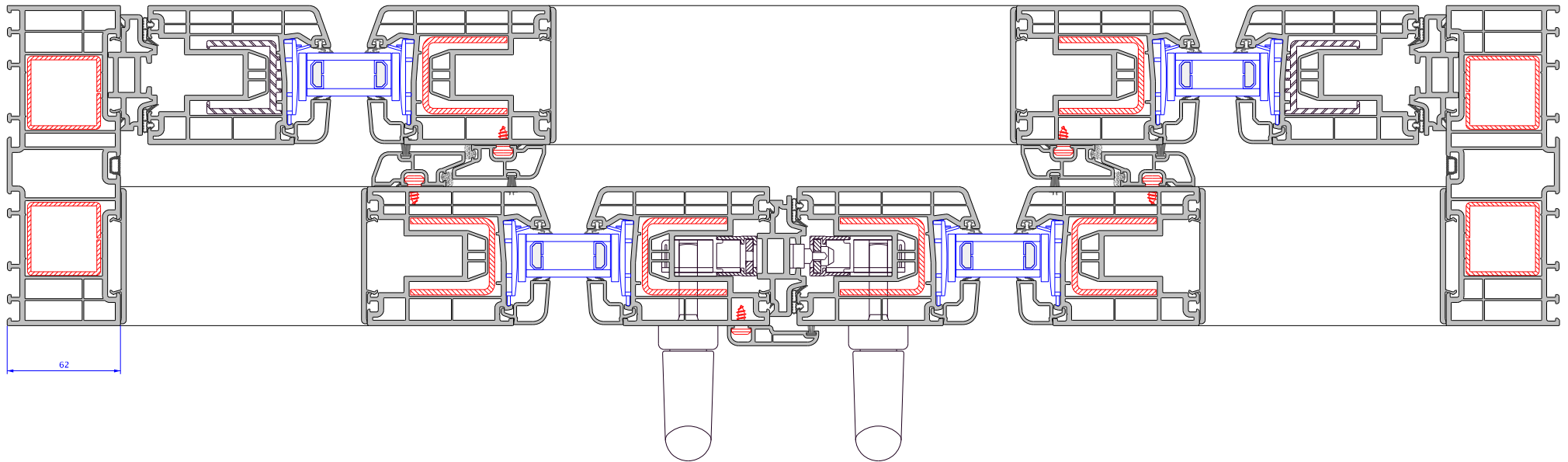
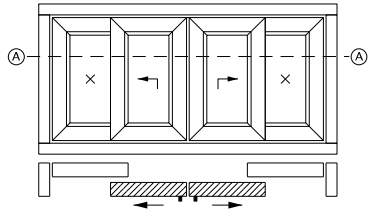

* As optional, 11467 can be used instead of 11685 that is shown in the details.

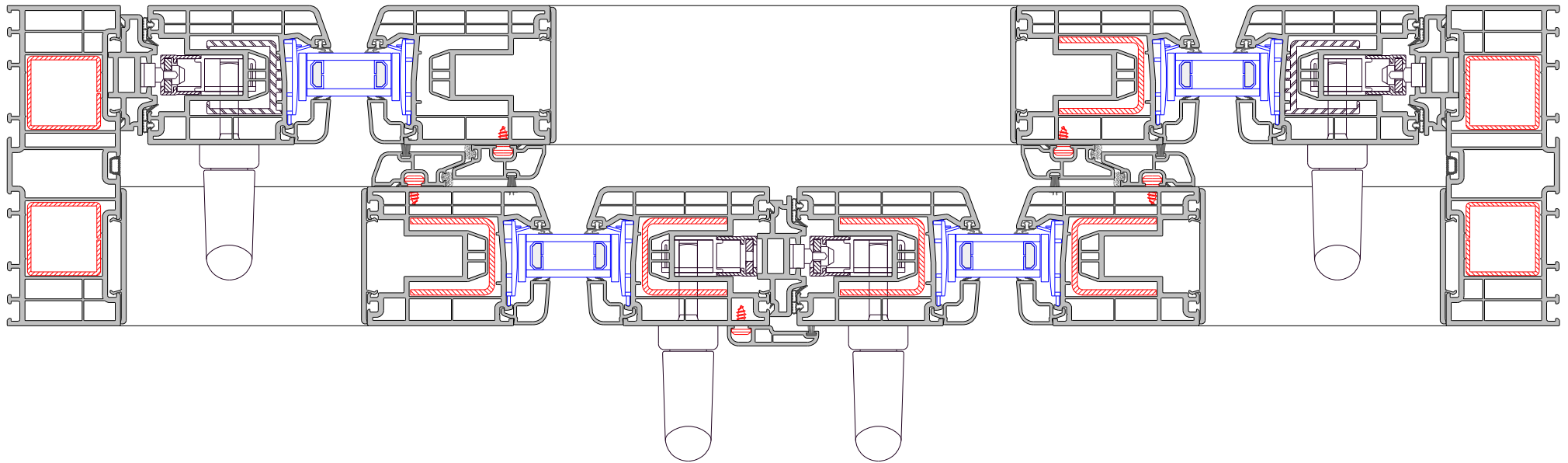
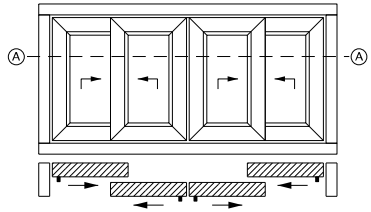

* As optional, 11467 can be used instead of 11685 that is shown in the details.

